

# JSC VertiClad

## Vertical Shiplap Weatherboard Cladding

Version 3.7 | February 2026



PREMIUM ARCHITECTURAL  
& BUILDING SOLUTIONS

## Contents

Introduction	3
Building Elements	4
Pre-Installation	7
Installation	8
Appendix	14

# INTRODUCTION

## GENERAL

This guide covers the scope of use, storage and handling, fixing, finishing and maintenance guidelines for JSC VertiClad Vertical Shiplap Weatherboard Cladding system.

JSC VertiClad is a cavity-based external wall cladding system comprising of:

- timber weatherboards finished with suitable coating
- H3.2 treated timber castellated cavity battens
- fascia boards, moulding profiles, and associated components

JSC weatherboards are available in a range of timber species and profiled to JSC specifications, consistent with [NZS 3617:1979](#) and [BRANZ BU411](#).

This guide covers the installation of JSC Vertical Shiplap weatherboards when fixed vertically over:

- **JSC-U 45×20 Non-Structural Cavity Battens** - 20mm thick castellated cavity battens; or
- **JSC-H 45×45, JSC-V 45×45 and JSC 70×45 Structural Cavity Battens** - 45mm thick castellated cavity battens.

For direct fix installation of JSC weatherboards refer to Acceptable Solution E2/AS1.

For Building Code regulations, refer to [VertiClad Design Guide](#).

## SCOPE AND LIMITATION OF USE

It is the specifier's responsibility to ensure that:

- the details in this specification are appropriate for the intended application, and
- additional detailing is obtained for a specific design or any areas that fall outside the scope of our VertiClad CodeMark certificate [CMNZ 30084](#).

JSC VertiClad system must be installed by a suitably qualified and experienced trade person. Where Restricted Building Work (RBW) applies, the installer shall be a Licensed Building Practitioner (LBP) or supervised by an LBP.

# BUILDING ELEMENTS

## STRUCTURE AND FRAMING

The performance and appearance of the cladding system rely on the substrate. JSC cladding systems are designed for timber wall framing. However, JSC 45mm Cavity Battens can also be fixed to structures outside of [NZS 3604:2011](#). 45mm Cavity Batten fixings should be determined by an engineer based on fixing tensions required on [JSC Structural Cavity Batten Fixing Guide](#).

Before installation, ensure the substrate is straight and true. Timber framing must be within the framing tolerances of [NZS 3604:2011](#) Section 2.2 and Table 2.1. For specific requirements relating to support for timber weatherboard cladding, refer to Sections 8 and 11 of [NZS 3604:2011](#).

If it is an existing building, the primary structure must be suitable for the intended building work.

## WALL UNDERLAY

Wall underlay must comply with [E2/AS1 Table C.2.1.1](#) and [E2/AS1 9.1.6](#). Alternatively, a wall underlay with a Product Certificate (CodeMark) or a BRANZ Appraisal is acceptable provided the conditions of use and scope comply.

Wall underlays (flexible or rigid) shall have a compliant and compatible flexible flashing tape applied to head and sill framing in accordance with [E2/AS1 4.2.12](#) and opening reveals as per [E2/AS1 9.1.4](#).

## CAVITY BATTENS

**JSC-U 45×20 Non-Structural Cavity Battens** are universal cavity battens that can be used either vertically or horizontally. Non-structural cavity battens must be fitted over the nogs and spaced at maximum 480mm centres.

**JSC-H 45×45, JSC-V 45×45 and JSC 70×45 Structural Cavity Battens** are structural cavity battens that allow additional options to create deeper window reveals and other design elements. Refer to [JSC Structural Cavity Batten Fixing Guide](#) for more information on spacings and fixings.

JSC castellated cavity battens are made of H3.2 CCA or MCA treated Radiata Pine which aligns with the principle that the minimum durability for building elements that are enclosed is greater than that for accessible elements.

The top and bottom edges of JSC cavity battens are bevelled to direct moisture away from the building. The front and the back face of the batten have castellations at regular intervals to allow pressures to equalise, moisture to drain, and improve air circulation to aid evaporation.

Proper ventilation is crucial to ensure airflow through the cavity, preventing moisture buildup that could cause damage to the structure like rot, mould, or decay.

**TABLE 1 - CAVITY BATTENS**

Profile	Description
<b>Non-Structural Cavity Batten</b>	
JSC-U 45mm x 20mm	18° bevelled edges and castellation on both faces
<b>Structural Cavity Batten</b>	
JSC-H 45mm x 45mm	18° bevelled edges and castellation on both faces
JSC-V 45mm x 45mm	Square edges and castellation on both faces
JSC 70mm x 45mm	18° bevelled edges and castellation on both faces

## INTER-STOREY JUNCTIONS

Inter-storey junctions in cladding are required for walls with a maximum of 7 metres in height or over two storeys as per [E2/AS1 Paragraph 9.1.8.4](#).

## VERTICAL CONTROL JOINT

For long, uninterrupted walls in high wind zones or buildings that are two storeys or taller, control joints should be placed every 6 metres to accommodate building movement across the wall.

## GROUND CLEARANCE

As per [E2/AS1 Paragraph 9.1.2](#) and [Table 9.1.2.1](#), the cladding should, at the ground level:

- Extend past the bottom plate on a concrete slab or bottom of bearer or lowest part of timber floor framing by 50mm
- Finish a minimum of 100mm above paved surface or 175mm above unpaved surface, and
- Have a minimum 35mm clearance to roof claddings and decks.

## DECKS AND DECORATIVE ELEMENTS

Ensure a gap for drainage and cleaning when attaching elements like letterboxes, pergolas, or decorative features to or close to the cladding. E2/AS1 requires a 12 mm minimum gap between slatted timber decks, stringers and external wall cladding, as well as against walls or balustrades for raised surfaces like tiles, pavers, or timber on weathertight decks.

## CAVITY CLOSER/VERMIN PROOFING

Cavity closer/vermin proofing should be specified in compliance with [E2/AS1 9.1.7.5](#), [9.1.7.6](#), [9.1.7.7](#) and [Figure 9.1.7.4A](#) to close off the bottom of the cavity. Ensure it is placed at the base of all walls, open horizontal

or raking junctions, and over openings (windows, penetrations, etc.). Size the cavity closer/vermin-proofing to fit the cavity dimensions.

## FLASHINGS

As per [E2/AS1 9.2.4](#):

- Flashing materials should comply with [E2/AS1 Table C.1.1.1A](#) and meet the compatibility of [E2/AS1 Table C.1.1.1B](#) and [Table C.1.1.1C](#).
- Ensure that flashing materials are compatible with both the window frame and cladding, including their fixings. Windows to comply with [NZS 4211:2022](#).

For detailed Building Clauses related to Building Elements, refer to [VertiClad Design Guide](#).

## NAIL FIXINGS

Annular grooved nails must be used to fix JSC VertiClad weatherboards. The nail length must allow a minimum of 30mm embedment into the framing for non-structural cavity batten and a minimum of 35mm embedment into structural cavity batten. JSC weatherboards must be pre-drilled with a slight upward slope (0-2°). The hole should be approximately 1mm smaller than the nail shank to reduce the risk of moisture entry.

**Note: For example, for a 75 × 3.25mm nail, use a 2.5mm drill bit.**

**Oil/Stain Finish** – Use annular grooved Rose Head, Pentagon Head or Flat Head.

**Paint Finish** – Use annular grooved Jolt Head, Flat Head, Pentagon Head or Rose Head.

In certain circumstances, screw fixing of weatherboards is acceptable. Please refer to the [JSC Screw Fixing Cladding Guide](#) for further information.

**TABLE 2 - FIXINGS INTO FRAMING**

Framing	Cavity Batten	Weatherboard Fixing
Timber Framing	45mm x 20mm (Non-Structural)	Annular grooved nail with 30mm minimum embedment into <b>timber frame</b>
	45mm x 45mm or 70mm x 45mm (Structural Fixing)	Annular grooved nail with 35mm minimum embedment into <b>cavity batten</b>

# PRE-INSTALLATION

**TABLE 3 - NAIL FIXINGS**

Species	Nail Material	
Western Red Cedar ( <i>Thuja plicata</i> )	316 Stainless Steel or Silicon Bronze	
Alaskan Yellow Cedar ( <i>Callitropsis nootkatensis</i> )		
Radiata Pine ( <i>Pinus radiata</i> )		
Nordic Pine ( <i>Pinus sylvestris</i> )		
JSC TMT Thermally Modified Species	Nail Material	
TMT Taiga	316 Stainless Steel or Silicon Bronze	Flat Head, Rose Head or Pentagon Head only
TMT Taxon		
TMT Amba		
TMT ThermoPine		
TMT ThermoPine - H3.2 (MicroPro® treated)		

**Notes:**

- Silicone bronze fixings may cause copper leaching. This effect is more noticeable with lighter finishes. It is aesthetic and does not compromise the durability of the fixing.
- For the use of any alternative fixing of equivalent properties refer to [E2/AS1 Table C.3.1.1](#) and to [E2/AS1 Table C.1.1.1A](#) for alternative material selection.
- JSC recommends fixing materials as per **Table 3 - Nail Fixings**, as they will at least match the life of the cladding (E2/AS1 allows the use of galvanised fixings, although JSC does not endorse their use).
- Jolt head nails are only suitable for paint finished weatherboards.
- For buildings located in exposure 'Zone D'; 316 stainless steel fixings must be used as per [NZS 3604:2011](#).

**BUILDING CONSENT DOCUMENTS**

Ensure that the Approved Building Consent plans are on-site. Follow the approved plans and communicate any deviations to the plans with the designer first before making any changes.

**MOISTURE MANAGEMENT**

As per [NZS 3602:2003 Table 4](#) the moisture content must be below 20% for framing and between 14-18% for timber cladding at the time of weatherboard installation. Before installation, check the moisture content using a moisture meter, testing 5% of the boards (minimum 10 boards) at the centre of the length and middle of the board. Do not start fixing JSC weatherboards until 90% of the readings meet the required range.

**HEALTH AND SAFETY**

When handling JSC products or using tools, use appropriate PPE; including but not limited to eye, ear and respiratory protection for you and others who could be affected. Cut weatherboards in well-ventilated areas. Dispose of offcuts and sawdust of treated and coated timber, and chemical products such as coatings and adhesives in accordance with the manufacturer's instructions and local council requirements. For more information refer to [JSC Products - Site Health & Safety Information](#).

**DELIVERY, STORAGE, AND HANDLING**

Correct handling and storage of JSC weatherboards are critical for best performance, ease of installation and warranty compliance.

JSC products should be delivered dry, unmarked, and undamaged from freight and handling. All deliveries should be inspected upon arrival. Delivery should be scheduled to minimise onsite storage time. All JSC products should be lifted off the truck by hoist or hand.

If unloading by crane or hiab, ensure there is a minimum of two well spaced load points to avoid excessive flexing.

**Note:** When using slings or chains, packers should be used to spread the load and protect the boards.

Stack weatherboards horizontally in a dry area, clear of the ground by 100mm and supported on dry and clean timber bearers at a maximum of 900mm centres.

Keep weatherboards dry; either by storing within an enclosed building or use an additional weatherproof cover as a secondary protection to JSC packaging wrap if stored outside. Ensure that there is sufficient airflow to avoid condensation. Do not store weatherboards over standing water or vegetation. Storing weatherboards in damp or uncovered areas increases the risk of moisture absorption. If weatherboards become wet, allow them to fully dry to the recommended moisture content before installation.

Take extra care to protect weatherboard edges and surfaces, particularly during installation.

**PRIMARY STRUCTURE AND WALL UNDERLAY**

Ensure that the substrate is straight and true. Confirm the timber framing has been constructed in accordance with the building consent and construction details, or in the case of an existing building, it is suitable for the intended building work.

The selected wall underlay and flexible tape system must be installed in accordance with the underlay and tape manufacturer's instructions prior to the installation of the cavity battens.

The flexible underlay can be restrained from bulging into the drained cavity by applying polypropylene tape at 300mm centres.

Rigid air barriers must be installed in accordance with NZS Acceptable Solution E2/AS1 and be overlaid with flexible tape over trimmed openings.

Trimmed openings are to be prepared as per [E2/AS1 Paragraph 9.1.4](#).

Stud centres must be spaced at a maximum of 600mm apart.

If installing **JSC-U 45×20 Non-Structural Cavity Battens**, nog centres must be spaced at a maximum of 480mm apart.

If installing **JSC-H 45×45** and **JSC 70×45 Structural Cavity Battens**, refer to [JSC Structural Cavity Batten Fixing Guide](#) for spacings and fixing requirements.

### COATING

JSC weatherboards must be coated using a suitable coating (exterior grade timber cladding coating — refer to the manufacturer’s guidance for use and suitability) and applied according to the manufacturer’s specification.

Weatherboard coating is done in two phases:

- Base coat(s) applied to all four sides before installation; and
- Top coat(s) applied after installation.

Weatherboards can be supplied either pre-finished with a factory-applied base coat or raw. If supplied raw, a base coat(s) must be applied on-site to all sides and cut ends before installation. **Note: Only weatherboards coated on all sides in suitable coating comply with JSC CodeMark certification.**

### Pre-Coated Weatherboards

JSC highly recommends a factory-applied base coat for a premium finish on all sides. This controlled process reduces weather delays, human error, and contamination from dust and debris.

No claims will be accepted for contamination on weatherboards delivered uncoated.

## INSTALLATION

**JSC VertiClad System must be installed by a suitably qualified and experienced trades person. Where Restricted Building Work (RBW) applies, the installer shall be a Licensed Building Practitioner (LBP) or supervised by an LBP.**

### On-Site Coating

When weatherboards are ordered raw, apply the base coat(s) and allow it to dry before installation.

#### Paint or Stain applications:

- Before installation, prime all four sides of the weatherboards with a suitable coating according to the coating manufacturer’s specification.
- During installation, all the cut ends must be coated twice.

#### Paint applications:

- Before installation and after applying the base coats, apply the first top coat to face and shown edges to minimise any colour difference due to lateral shrinkage.
- After installation, apply 2-3 top coats on all visible areas of cladding. Refer to the [Finishing](#) section of the document for further information.

When using Radiata Pine weatherboards, the paint colour’s Light Reflective Value (LRV) must be at least 45% to minimise dimensional movements that can cause cupping and splitting.

**Note:** Follow coating manufacturer specifications at all times.

**Note:** For information on maintaining coatings refer to [JSC Maintenance Guide](#).

### CUTTING AND INSTALLING CAVITY BATTENS

Cut horizontal and vertical cavity battens at a 20–30° angle, ensuring they slope away from the framing. For vertical battens, both the top and bottom ends must be angled to direct moisture away from the framing.

Cut cavity battens through the full thickness. Do not cut through a castellation. Cavity battens must have full contact with the back of the weatherboard and wall underlay at each end of the batten.

#### Vertical Cavity Battens



**Incorrect cut:** cavity batten cut through front rebate



**Correct cut:** cavity batten on angle and cut through the full thickness of the batten

#### Horizontal Cavity Battens

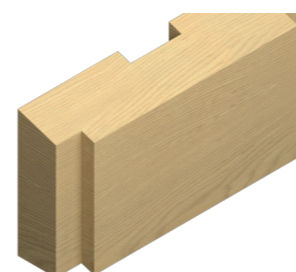

**Incorrect cut:** cavity batten cut through front rebate



**Correct cut:** cavity batten on angle and cut through the full thickness of the batten

When installing cavity battens, take into account all accessory components that can add to cavity thickness, such as cavity closures and flashings. Install cavity battens at the same plane to ensure the back of the boards makes full contact with them. If necessary, adjust the thickness of the cavity battens with a planer (up to a maximum of 5mm) to properly accommodate these components.

On internal corners, avoid tearing the wall underlay with the cavity batten’s sharp bevelled edge. Flashing tape is recommended. Cavity batten can be planed to remove sharp edges if necessary.

To better support flashings, small mouldings, or narrow weatherboards, we recommend staggering the castellations of the cavity battens in relation to one another.

Ensure cavity battens are spaced 5-10mm from each other on ends/joints, internal and external corners, and when parallel.

Fastenings must penetrate the cavity batten through its thickest points, not through the castellations. Stagger the fixings on either side of the cavity batten’s centre line to avoid interference with weatherboard fixings.

### Non-Structural Cavity Battens

**JSC-U 45×20 Non-Structural Cavity Battens** are horizontally fixed through the wall underlay to the nogs (at 480mm centres max.) Refer to [E2/AS1 Table C.3.1.1](#).

Before installing the cladding, temporarily fix the **JSC-U 45×20 Non-Structural Cavity Battens** with stainless steel 50mm clouts or similar to the timber frame.

**Note:** JSC do not endorse the installation of JSC-U 45×20 Non-Structural Cavity Battens over other substrates other than timber framing.

Install **JSC-U 45×20 Non-Structural Cavity Battens** horizontally with the 18° bevels sloping away from the wall underlay towards the back of the weatherboard, ensuring water is shed away from the framing.

For Very High (VH) and Extra High (EH) wind zones (as per [NZS 3604:2011](#)), a solid batten (non-castellated) is required down one side of an external corner to provide pressure isolation between different walls.

### Structural Cavity Battens

The **JSC-H 45×45**, **JSC-V 45×45** and **JSC 70×45 Structural Cavity Battens** become structural wall components.

Horizontal structural cavity battens are to be structurally fixed to the wall framing. Refer to [JSC Structural Cavity Batten Fixing Guide](#) for fastenings and layout options.

When joining 45mm thick cavity battens, our preferred method is to cut the joining ends of the battens at a 30° angle and position them over double studs with an 8mm (+/-2mm) gap between the joining ends. Ensure that the cavity batten fixings will not interfere with the weatherboard fixings.

If joining over double studs is not possible, battens can be joined over a single stud. In this case, the joining ends of the battens should also be cut at a 30° angle, but with no gap left between them.

In both methods, we recommend staggering the junctions.

### FLASHINGS

Flashings at corners, openings, and wall intersections must be installed to prevent water from entering the cavity.

When installing rigid metal flashings at corner details, it is essential to pre-drill the flashing. The corner moulding fixings should only penetrate the cavity battens—there is no need for these fixings to go through to the timber framing.

For flexible flashings, such as uPVC, ensure that the moulding fixings are embedded directly into the timber framing for proper support.

When using 45mm structural cavity battens, do not use flexible corner flashings. The cavity batten positioning will not provide the necessary support for these flashings.

### WEATHERBOARD INSTALLATION

Before installing weatherboards:

- Ensure weatherboards are dry, free of contamination, and have a consistent moisture content within the specified range.

- Ensure weatherboards have a suitable exterior grade coating on all four sides, including cut ends.
- Optimise board lengths to minimise wastage and joins.
- Remove any loose or bark-encased knots or timber defects that may allow moisture to enter.
- Install required flashings.
- Use back flashing behind the cladding at corners, joints, and junctions for weathertightness.
- Install cavity closure continuously around the bottom of the cavity.
- Keep openings in cavity closer/vermin-proofing clear for effective draining and venting.
- Ensure head flashing stop ends are in place.

Start installing JSC Vertical Shiplap Weatherboards at the corner of the wall. Boards must be installed flat and plumb.

Accurate packers should be used to achieve the negative space between boards (at the face of the boards) and to align the weather grooves and set the expansion gap. Refer to **Figure 1 and Figure 2 - Typical Vertical Shiplap Weatherboard Installation**. During installation, cut ends must be double coated.

Use a laser or mechanical device to accurately set-out all nailing.

JSC weatherboards must be pre-drilled with a slight upward slope (0-2°). The hole should be approximately 1mm smaller than the nail shank to reduce the risk of moisture entry.

**Note: For example, for a 75 × 3.25mm nail, use a 2.5mm drill bit.**

When using **JSC-U 45×20 Non-Structural Cavity Battens**, weatherboard fixings provide the true primary fixing for the cavity batten. Fix the weatherboards with a minimum of 30mm penetration into the timber wall framing as per [E2/AS1 Table C.3.1.1](#) and [Table 2 - Fixings into Framing](#).

When using **JSC-H 45×45**, **JSC-V 45×45** or **JSC 70×45 Structural Cavity Battens**, fix the weatherboards with a minimum of 35mm penetration into the cavity battens.

Single fix each weatherboard at 30-35mm from the overlapping edge to achieve a minimum of 30mm

fixing penetration into the timber framing or 35mm into the structural cavity batten. Single fixing allows the underlap to move, preventing stress from timber expansion and contraction.

**NOTE: Scribes must be bedded in sealant to weatherboards for weathertightness.**

Refer to [Table 2 - Fixings into Framing](#)

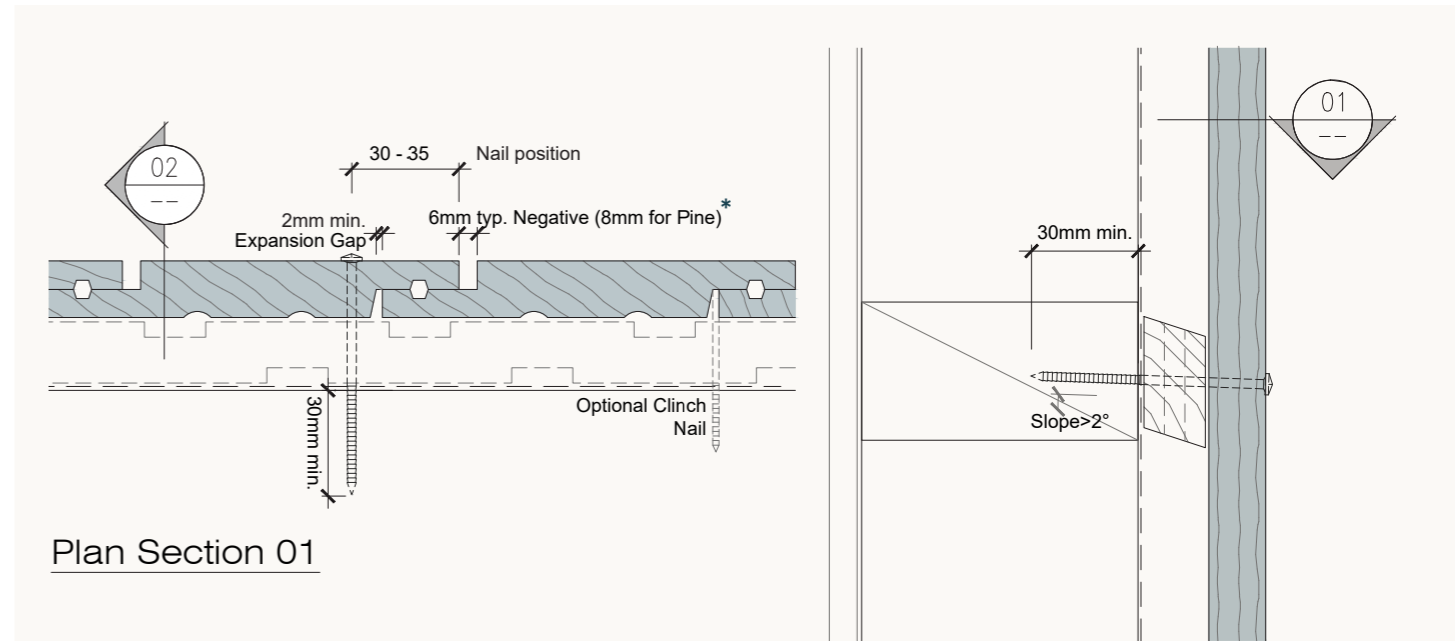

Plan Section 01

Cross Section 02

**Figure 1 - Typical Vertical Shiplap Weatherboard Installation**  
20mm non-structural cavity battens on Timber Framing

\* *VertiClad profiles are typically installed with a 6mm negative detail. Note that some profiles differ — for example, Radiata Pine APJ730 and APJ731 require an 8mm negative detail. Always confirm the required negative against the specific profile before installation.*

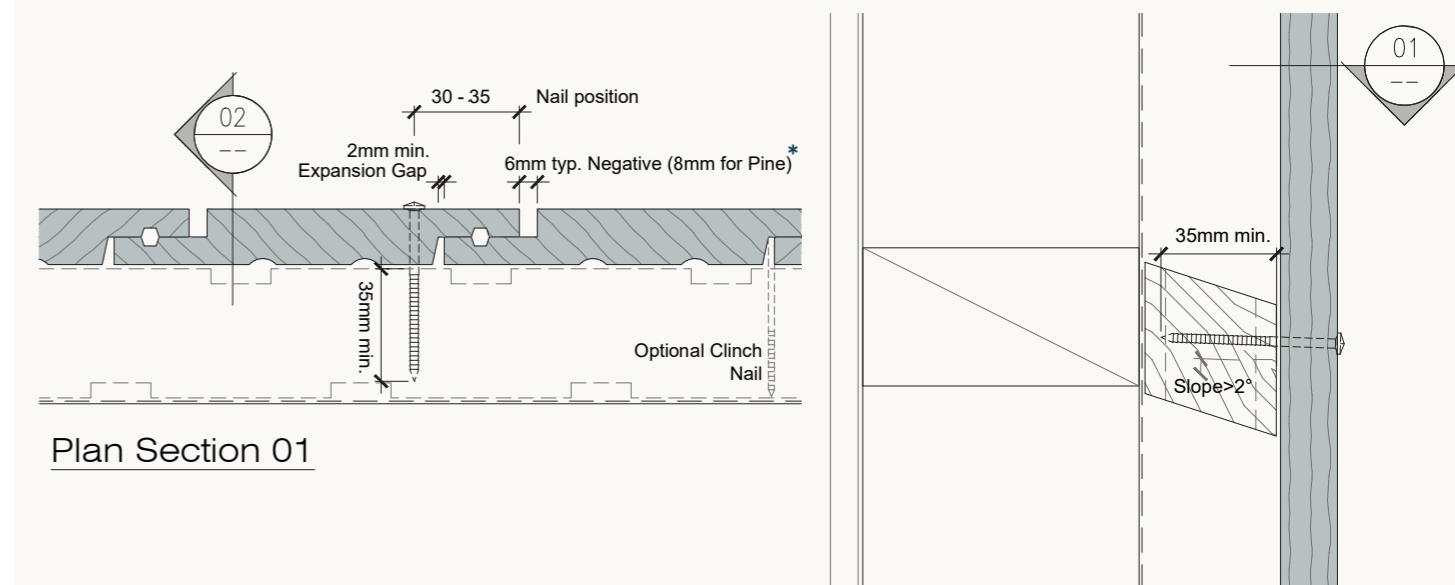

Plan Section 01

Cross Section 02

**Figure 2 - Typical Vertical Shiplap Weatherboard Installation**  
45mm structural cavity battens on Timber Framing

**When fixing cavity battens to framing, avoid fixing them on their centre line. Stagger the cavity battens fixings to prevent interference with weatherboard fixings.**

**Note:** Exposed Board Ends - Where vertical weatherboards have an exposed bottom edge such as at the Bottom Plate, Window Heads, Inter-storey and Overhead Soffit junctions, the bottom of the boards should be cut back at 15 degrees to form a drip edge. The cut end should be coated 150-200mm from the bottom edge, up the back of the board. In the case of paint, sharp edges should be eased, the primer should be brushed thoroughly into the cut end, up the back and then top-coated. The areas where board ends are visually exposed must be checked as part of every coating maintenance inspection.

Do not pin the laps or face of the board (this characterises double fixing). Always single-fix the board. Never pin the laps.

### Clinch Nails (Optional)

If desired, 40mm x 2.0mm stainless steel clinch nails can be used to secure the boards until they are nailed off.

### Guidelines for Using Clinch Nails:

- Clinch nails are optional. They serve as an aid to installation only and do not contribute to fixing or affect the overall set-out of the weatherboards.
- Clinch nails cannot be fully relied upon as a layout gauge. For accurate alignment of weather grooves and setting the expansion gap, use a precise packer to set the negative detail.
- For shorter boards, place one clinch nail in the middle and use additional clinch nails to maintain even spacings. Ensure they are under 1.8 metres apart.
- Clinch nails do not reduce the number of

weatherboard nails required.

### Corner Details

When installing cladding boards at corners, avoid using wide boards (e.g. 200mm wide) that aren't supported by adjacent boards. Wide boards require special considerations and layout planning before installation.

For corners, cut the wide boards narrower—ideally to a maximum of 65mm wide for overlap boards, and 90mm maximum for underlap boards. Boards to be fixed as per usual (30-35mm from the overlapping edge). Refer to **Figure 3** and **Figure 4**.

**Wide boards should not be used on corners due to their tendency to lift. The layout must be planned in advance. Use a combination of narrow boards if necessary to achieve reliable corner details. In cases where cutting the boards is not possible, contact JSC.**

Consider using a self-adhered membrane at corners to protect against water ingress, especially if a board lap lifts over time, e.g. VaproShield membrane.

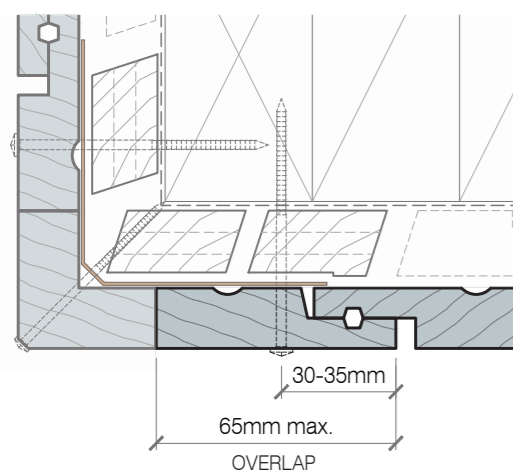

**Figure 3** - Overlap board to be maximum 65mm wide with fixing point as per usual

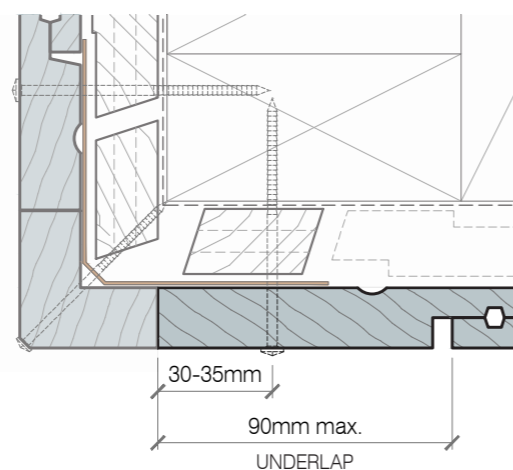

**Figure 4** - Underlap board to be maximum 90mm wide

### Scribers

Ensure scribes extend at least 5mm past the joinery sill and are bevelled back to the wall at an angle of 30-45°. Keep in mind that scribes and small decorative profiles are more prone to splitting and decay. They may only last 5 years in certain situations. Yearly maintenance cycles should be followed to keep integrity and to determine if re-coating, or replacement is needed.

Fix scribes and decorative trims using short screws or nails (35-50mm long) that do not penetrate the framing.

### FINISHING

#### Oil /Stain Finish

- All cut ends shall be double coated during installation to protect against moisture uptake.
- Finish the nail heads flush onto and not into the board surface.
- Do not over-drive the nail head that crushes the timber surface beneath and around the nail.
- Top coat of selected suitable stain should be applied to the visible surfaces after installation as per the coating manufacturer's instructions.

#### Paint Finish

- All cut ends and uncoated surfaces shall be double coated with a suitable alkyd or acrylic based primer during installation to protect against moisture uptake.
- Remove all sharp edges to provide a radius to minimise stress on the paint film.
- Nails are to be punched and the holes to be primed promptly.
- Fill holes with a suitable filler. Filled holes are to be primed again and sanded once dry.
- Ensure the surface is clean and free from any

contaminants, including oils or non-paintable sealants before applying the top coats.

- At least two top coats of suitable acrylic paint should be applied after installation as per the coating manufacturer's instructions.

**Note:** Always ease sharp edges. Paint does not adhere well to sharp edges and is prone to cracking. Prime all cut ends thoroughly to seal the timber, prevent moisture ingress, and reduce the risk of tannin bleed affecting topcoats. Follow the coating manufacturer's specifications. Example: When cutting a 15° drip edge at window heads or bottom boards, the resulting sharp edge at the face of the board must be slightly rounded. This allows the paint film to build properly and prevents early coating failure.

**Note:** For paint finish weatherboards, JSC recommends external corner junctions to have box corners or J42 Corner Moulding. Refer to JSC Technical details.

### QUALITY CHECK

On completion, visually inspect all sides of the building to ensure that the cladding system is properly installed. The building owner should be advised of all maintenance requirements.

### MAINTENANCE

Building owners are responsible for the maintenance of their JSC weatherboards. Annual inspections must be made to ensure that all aspects of the cladding remain in a weatherproof condition. Repair to damaged areas and maintenance where signs of deterioration are evident, must be addressed promptly. Repairs to sealants, coatings, flashings, scribes, decorative elements and weatherboards must follow the relevant manufacturer's instructions. Weatherboards should be washed when surface dirt, pollen, or organic matter accumulates. In environments such as bush areas or locations with high seasonal pollen, cleaning may be required more frequently. For further information refer to the latest [JSC Maintenance Guide](#).

# APPENDIX 1

DETAIL NUMBER	DETAIL TITLE	VERTICLAD SYSTEM ACCESSORIES
VS10	Window Head Detail	<p><b>Head Flashing</b></p> <ul style="list-style-type: none"> <li>Sizes as per <a href="#">E2/AS1 Table 4.5.1.1</a></li> <li>In accordance with <a href="#">E2/AS1 Paragraph 9.1.10.4</a> or window manufacturer's instructions</li> <li>Usually supplied by joinery companies</li> <li>JSC do not recommend hooks or hems. Therefore, the flashing upstand dimensions must be increased by 25mm in accordance with <a href="#">E2/AS1, Paragraph 4.4.3</a>.</li> <li>JSC recommends a flexible cavity closer at window heads to accommodate accessory buildup and batten machining</li> </ul> <p><b>Window Joinery</b></p> <ul style="list-style-type: none"> <li>To be installed in accordance with <a href="#">E2/AS1 Paragraph 9.1.9</a> and <a href="#">SNZ TS 4211:2022</a> and be compliant with <a href="#">BPS Subsection 4.4.1</a></li> </ul> <p><b>J Mould</b></p> <ul style="list-style-type: none"> <li>65mm x thickness of the weatherboard</li> </ul>
VS11	Window Sill Detail	
VS12	Window Jamb Detail - Scriber	
VS13	Window Jamb Detail - No Scriber	
VS30	Square Utility Head Detail	
VS31	Square Utility Sill Detail	
VS32	Square Utility Jamb Detail	
VS40	Weatherboard Scarf Joint	<p><b>Back Flashing</b></p> <ul style="list-style-type: none"> <li>Recommended min. 50mm coverage from any butt joint</li> <li>Materials to comply with <a href="#">E2/AS1 Table C.1.1.1A</a></li> <li>For PVC or other flexible materials ensure flashing maintains contact with the back of cladding. If required, use extra cavity batten</li> </ul>
VS41	Vertical Control Joint	
VS42	Base of Wall - Concrete	<p><b>Cavity Closer</b></p> <ul style="list-style-type: none"> <li>Size to suit cavity</li> <li>To comply with <a href="#">E2/AS1 9.1.7.5, 9.1.7.6, 9.1.7.7</a> and <a href="#">Figure 9.1.7.4A</a>; or</li> <li>Covered by CodeMark or BRANZ Appraisal provided the conditions of use and scope comply</li> <li>Minimum vent 1000mm<sup>2</sup> / linear meter</li> </ul>
VS43	Base of Wall - Timber	
VS44	Pipe Penetration	<p><b>Pipe Penetration Boot</b></p> <ul style="list-style-type: none"> <li>To comply with <a href="#">E2/AS1 Paragraph 9.1.8.3</a>; or</li> <li>Covered by CodeMark or a BRANZ Appraisal used within the scope</li> <li>To be installed per manufacturer's specifications</li> </ul>
VS50	External Corner - J40	
VS51	3D - External Corner - J40	
VS52	External Corner - APJC5	
VS53	3D - External Corner - APJC5	

DETAIL NUMBER	DETAIL TITLE	VERTICLAD SYSTEM ACCESSORIES
VS54	External Corner - J42	<p><b>Corner Flashing</b></p> <ul style="list-style-type: none"> <li>Sizes as per <a href="#">E2/AS1 Table 4.5.1.1</a> and <a href="#">Paragraph 4.4.3</a></li> <li>Materials to comply with <a href="#">E2/AS1 Table C.1.1.1B</a> and <a href="#">Table C.1.1.1C</a></li> <li>For PVC or other flexible materials, ensure flashing maintains contact with the back of cladding. If required, use extra cavity batten</li> <li>When using 45mm structural cavity battens, do not use flexible corner flashings. The cavity batten positioning will not provide the necessary support for these flashings.</li> </ul>
VS55	3D - External Corner - J42	
VS60	Internal Corner - J44	
VS61	3D - Internal Corner - J44	
VS62	Internal Corner	
VS63	3D - Internal Corner	
VS64	External Corner - Box Corner	
VS65	3D - External Corner - Box Corner	
VS70	Base of Wall - Membrane Roof	
VS71a	Parapet Saddle Flashing - Stage One	
VS71b	Parapet Saddle Flashing - Stage Two	
VS71c	Parapet Saddle Flashing - Stage Three	
VS71d	Parapet Saddle Flashing - Stage Four	
VS75	Parapet Detail	
VS77	Decorative Bracket - Batten Detail	
VS80	Inter-storey Detail	<p><b>Z Flashing</b></p> <ul style="list-style-type: none"> <li>JSC do not recommend hooks or hems. Therefore, the flashing upstand dimensions must be increased by 25mm in accordance with <a href="#">E2/AS1, Paragraph 4.4.3</a></li> <li>In accordance with <a href="#">E2/AS1 Paragraph 9.1.8.4</a></li> </ul>
VS81	Apron Flashing Roof to Wall Junction	
VS82	Soffit Detail at Wall	
VS83	Soffit Detail at Fascia	
VS84	Raking Soffit at Wall	
VS85	Gable Soffit Detail at Wall	

DETAIL NUMBER	DETAIL TITLE	VERTICLAD SYSTEM ACCESSORIES
VS90	Weatherboard Fixing - Plan Section	<b>Weatherboard Fixings - Stain Finish</b> <ul style="list-style-type: none"> <li>Materials to comply with <a href="#">E2/AS1 Table C.1.1.1B</a> and <a href="#">Table C.1.1.1C</a></li> <li>Fastener length and position per <a href="#">E2/AS1 Table C.3.1.1</a></li> <li>Stainless steel or silicon bronze annular grooved Rose Head, Pentagon Head and Flat Head</li> </ul> <b>Weatherboard Fixings - Paint Finish</b> <ul style="list-style-type: none"> <li>Materials to comply with <a href="#">E2/AS1 Table C.1.1.1B</a> and <a href="#">Table C.1.1.1C</a></li> <li>Fastener length and position per <a href="#">E2/AS1 Table C.3.1.1</a></li> <li>Stainless steel or silicon bronze annular grooved Jolt Head, Flat Head, Pentagon Head and Rose Head</li> </ul>
VS91	Weatherboard Fixing - Cross Section	
VS92	Apron Flashing Gutter to Wall	

## VERTICLAD SYSTEM ACCESSORIES

### Wall Underlay (Flexible or Rigid)

- To comply with [E2/AS1 Table C.2.1.1](#); or
- Wall underlays covered by CodeMark or a BRANZ Appraisal used within the scope
- Installed and handled per manufacturer's specification

### Flashing Tape

- To comply with [E2/AS1 Paragraph 4.2.12](#); or
- Product with a CodeMark or a BRANZ Appraisal used within the scope
- To be compatible with wall underlay

### Clouts

- Materials to comply with [E2/AS1 Table C.1.1.1B](#) and [Table C.1.1.1C](#)
- Nail length and position per [E2/AS1 Table C.3.1.1](#)
- Stainless steel

### Other Fixings

- Any other fixing shall comply with [NZS 3604:2011](#) for timber framing

### Sealant

- To comply with [E2/AS1 Paragraph 9.1.5](#)
- To be compatible with coating and other elements

### Coating

- Should be suitable to use as external cladding coating
- All weatherboards are recommended to be delivered to site with minimum of one coat of selected coating on all four sides
- Coat the cut ends with two coats wet on wet
- Subsequent coats are done after the installation
- Follow the manufacturer's specifications at all times

# APPENDIX 2

## EXTERNAL REFERENCE

- MBIE NZ Building Code Clause E2 External Moisture (refer to [www.building.govt.nz](http://www.building.govt.nz))
- Department of Building and Housing (DBH). Constructing Cavities for Wall Claddings (refer to [www.building.govt.nz](http://www.building.govt.nz))
- BRANZ Bulletin BU468 [December 2005] Fixing Timber Weatherboards (refer to [www.branz.co.nz/BU468](http://www.branz.co.nz/BU468))
- BRANZ [May 2015] Good Practice Guide: Timber Cladding (refer to [www.branz.co.nz](http://www.branz.co.nz))
- BRANZ Build 154-33- Build Right Structurally Fixed Cavity Battens (refer to [www.buildmagazine.org.nz](http://www.buildmagazine.org.nz))
- BRANZ Build 173-28- Build Right Coatings for Timber Weatherboards (refer to [www.buildmagazine.org.nz](http://www.buildmagazine.org.nz))
- BRANZ Bulletin BU531 [February 2011] Designing for Thermal and Moisture Movement (refer to [www.branz.co.nz/BU531](http://www.branz.co.nz/BU531))
- Window & Glass Association NZ (WGANZ) (refer to [wganz.org.nz](http://wganz.org.nz))
- NZS AS 1720.1:2022 (refer to [www.standards.govt.nz](http://www.standards.govt.nz))
- NZS 3604:2011 Timber-framed buildings (refer to [www.standards.govt.nz](http://www.standards.govt.nz))

**Disclaimer:** It is the responsibility of the designer/specifier to ensure the suitability and specification of any third-party accessories used with our cladding system. JSC is not liable for the installation of any components or accessories not supplied by us. If there is any uncertainty, please seek expert advice.

The related documents mentioned above were accurate and up to date at the time of writing this guide. However, please note that information may have changed since then, and we recommend verifying any external sources for the most current information.

## FOR TECHNICAL DRAWINGS & OTHER CLADDING RELATED DOCUMENTS

See our full set of detailed information covering the installation, profiles, certification, drawings, and species. Visit the related website page using the URL below or scan the QR code to access.

[Vertical Shiplap Cladding Website Page](#)



SCAN ME



PREMIUM ARCHITECTURAL  
& BUILDING SOLUTIONS

[jsc.co.nz](https://www.jsc.co.nz)

[TechHelp@jsc.co.nz](mailto:TechHelp@jsc.co.nz) | [Sales@jsc.co.nz](mailto:Sales@jsc.co.nz)

FIND JSC ONLINE



**AUCKLAND**

**(09) 412 2800**  
22 Sawmill Road  
Riverhead

**HAMILTON**

**0800 57 26 88**  
43 McKee Street  
Pukete

**WELLINGTON**

**0800 57 26 88**  
61 Seaview Road  
Seaview

**CHRISTCHURCH**

**(03) 348 9726**  
23 William Lewis Drive  
Sockburn