

TECHNICAL DRAWINGS

JSC VERTICLAD Vertical Shiplap Weatherboards Rigid Underlay 20mm Cavity Fix

ISSUE : 11/02/2026 | VERSION : 2.6

© J SCOTT & COMPANY LIMITED 2026



Eastern Beach Home | Matt Brew Architect
Photo: Jamie Cobel

CodeMark
CMNZ30084



jsc.co.nz
TechHelp@jsc.co.nz | (09) 412 2812

TYPE
VERTICAL SHIPLAP WB - 20mm CAVITY FIX

NAME
COVER SHEET

- TO BE READ IN CONJUNCTION WITH COMPLETE JSC VERTICLAD SYSTEM LITERATURE
- DETAILS MAY BE SUBJECT TO CHANGE WITHOUT NOTICE



SCAN IT FOR MORE
INFORMATION

DRAWING SCALE NTS	ISSUE DATE 11/02/2026
DRAWING NUMBER JSC 20CR VS01	VERSION 2.6

INDEX

ISSUE : 11/02/2026 | VERSION : 2.6

© J SCOTT & COMPANY LIMITED 2026

Sheet Number	Sheet Title
JSC 20CR VS01	COVER SHEET
JSC 20CR VS02	INDEX
JSC 20CR VS03	GENERAL NOTES
JSC 20CR VS04	RELATED DOCUMENTS
JSC 20CR VS10	Window Head Detail
JSC 20CR VS11	Window Sill Detail
JSC 20CR VS12	Window Jamb Detail - Scriber
JSC 20CR VS13	Window Jamb Detail - No Scriber
JSC 20CR VS30	Square Utility Head Detail
JSC 20CR VS31	Square Utility Sill Detail
JSC 20CR VS32	Square Utility Jamb Detail
JSC 20CR VS40	Weatherboard Scarf Joint
JSC 20CR VS41	Vertical Control Joint
JSC 20CR VS42	Base of Wall, Concrete
JSC 20CR VS43	Base of Wall, Timber
JSC 20CR VS44	Pipe Penetration
JSC 20CR VS50	External Corner - J40
JSC 20CR VS51	3D - External Corner - J40
JSC 20CR VS52	External Corner - APJC5
JSC 20CR VS53	3D- External Corner - APJC5
JSC 20CR VS54	External Corner - J42
JSC 20CR VS55	3D - External Corner - J42
JSC 20CR VS60	Internal Corner - J44
JSC 20CR VS61	3D - Internal Corner - J44
JSC 20CR VS62	Internal Corner
JSC 20CR VS63	3D - Internal Corner
JSC 20CR VS64	External Corner - Box Corner
JSC 20CR VS65	3D - External Corner - Box Corner
JSC 20CR VS70	Base of Wall, Membrane Roof
JSC 20CR VS71a	Parapet Saddle Flashing - Stage One
JSC 20CR VS71b	Parapet Saddle Flashing - Stage Two
JSC 20CR VS71c	Parapet Saddle Flashing - Stage Three
JSC 20CR VS71d	Parapet Saddle Flashing - Stage Four
JSC 20CR VS75	Parapet Detail
JSC 20CR VS77	Decorative Bracket - Batten Detail
JSC 20CR VS80	Inter Storey Joint
JSC 20CR VS81	Apron Flashing Roof To Wall Junction
JSC 20CR VS82	Soffit Detail at Wall
JSC 20CR VS83	Soffit Detail at Fascia
JSC 20CR VS84	Raking Soffit at Wall
JSC 20CR VS85	Gable Soffit Detail at Wall
JSC 20CR VS90	Weatherboard Fixing -Plan View
JSC 20CR VS91	Weatherboard Fixing - Cross Section
JSC 20CR VS92	Apron Flashing Gutter to Wall

CodeMark
CMNZ30084



jsc.co.nz
TechHelp@jsc.co.nz | (09) 412 2812

TYPE
VERTICAL SHIPLAP WB - 20mm CAVITY FIX

NAME
INDEX

• TO BE READ IN CONJUNCTION WITH COMPLETE JSC VERTICLAD SYSTEM LITERATURE
• DETAILS MAY BE SUBJECT TO CHANGE WITHOUT NOTICE



SCAN IT FOR MORE
INFORMATION

DRAWING SCALE NTS	ISSUE DATE 11/02/2026
DRAWING NUMBER JSC 20CR VS02	VERSION 2.6

GENERAL NOTES

ISSUE : 11/02/2026 | VERSION : 2.6

OVERVIEW :

JSC VertiClad is a cavity based external wall cladding system comprising of:

- Timber weatherboards finished with high quality exterior grade coating
- H3.2 treated timber castellated cavity battens
- Fascia boards and moulding profiles

This documentation covers the installation guide for fixing JSC Vertical Shiplap weatherboards over JSC-U 20mm thick castellated cavity battens.

SCOPE OF USE:

- This document is for use within the scope of JSC VertiClad Vertical Shiplap Weatherboard Cladding System technical documentation and Code Compliance CodeMark certificate CMNZ 30084.
- For scope, conditions and limitations of use refer to CodeMark certificate [CMNZ 30084](#).
- Details are subject to change without notification and only the current version is compliant. Refer to [jsc.co.nz](#) at the time of use for the current documentation.
- The designer/specifier must be satisfied that these details are applicable for their intended use.

FIXING SPECIFICATION:

- Western Red Cedar, Alaskan Yellow Cedar, Radiata Pine and Nordic Pine, TMT Taiga, TMT Taxon, TMT Tuscan, TMT Amba, TMT ThermoPine and TMT ThermoPine H3.2: Fixing material to be 316 Stainless Steel or Silicon Bronze annular grooved nails
- For the use of any alternative fixing of equivalent properties refer to [E2/AS1 Table C.3.1.1](#) and to [E2/AS1 Table C.1.1.1A](#) for alternative material selection.
- JSC recommends nail materials as per [VertiClad Installation Guide Table 3 - Nail Fixings](#), as they will at least match the expected life of the cladding. E2/AS1 allows the use of galvanised fixings, although JSC does not endorse their use.
- Jolt head nails are only suitable for paint finished weatherboards.
- For buildings located in exposure 'Zone D', 316 stainless steel fixings must be used as per [NZS 3604:2011](#).

PRE INSTALLATION:

- Weatherboards must be dry and free of any contamination.
- Board lengths must be optimised prior to the installation to avoid any unnecessary wastage and joints.
- Any loose, bark encased knots, or other timber defects need to be removed.
- Weatherboards must be coated with suitable exterior coating on all sides in accordance with coating manufacturer's specification.

INSTALLATION:

- JSC VertiClad System must be installed by a suitably qualified and experienced trade person. Where Restricted Building Work (RBW) applies the installer shall be a Licensed Building Practitioner (LBP) or supervised by LBP.
- Compatibility of materials as per [Tables C.1.1.1A - C.1.1.1C E2/AS1](#).
- Rigid and flexible underlay as per [E2/AS1 Table C.2.1.1](#) and [Clauses 9.1.4 to 9.1.6 E2/AS1](#) or proprietary approved alternative.
- The weatherboard system shall incorporate joinery that meets the requirements of New Zealand Building Code for the relevant building wind zone or wind pressure.
- Where weatherboards have an exposed bottom edge, the back of the boards should be cut with a 15° drip edge and the cut end should be coated to 150-200mm up from the bottom edge.
- Cavity closer/vermin proofing must be installed continuously around the bottom of the cavity positioned to give a 15mm min. drip edge to cladding.
- Cavity closer/vermin proofing openings must be kept clear and unobstructed to maintain draining and venting of the cavity.
- Windows and doors to be installed as per manufacturer's specifications, head flashing stop ends must be in place. Flashings as per [E2/AS1 Part 4](#).
- Flashings as per [E2/AS1 Part 4](#). at corners, doors, windows and wall intersections must be installed to prevent water from crossing the cavity.
- Sealant to be compatible with the final coating system and to be applied as per manufacturer's instructions and specifications. For JSC Coating products refer to [JSC Coatings Wood Oil Range Guide](#).

MAINTENANCE:

- Annual inspection and cleaning followed by repair to any damaged areas. Refer to [JSC Maintenance Guide](#).

CodeMark
CMNZ30084



DRAWING SCALE NTS	ISSUE DATE 11/02/2026
DRAWING NUMBER JSC 20CR VS03	VERSION 2.6

RELATED DOCUMENTS

ISSUE : 11/02/2026 | VERSION : 2.6

© J SCOTT & COMPANY LIMITED 2026

- MBIE NZ Building Code Clause E2 External Moisture (refer to [E2 External moisture](#))
- Department of Building and Housing (DBH). [Constructing cavities for wall claddings](#)
- BRANZ Bulletin BU468 [December 2005] Fixing Timber Weatherboards (refer to www.branz.co.nz/BU468)
- [BRANZ \[May 2015\] Good Practice Guide: Timber Cladding](#)
- [BRANZ Build 154-33- Build Right Structurally Fixed Cavity Battens](#)
- [BRANZ Build 173-28- Build Right Coatings for Timber Weatherboards](#)
- [BRANZ Bulletin BU531 \[February 2011\] Designing for Thermal and Moisture Movement](#)
- Window & Glass Association NZ - WGANZ (www.wganz.org.nz)
- [NZS AS 1720.1:2022](#)
- [NZS 3604:2011 Timber-framed buildings](#)

Disclaimer: It is the responsibility of the designer/specifier to ensure the suitability and specification of any third-party accessories used with our cladding system. JSC is not liable for the installation of any components or accessories not supplied by us. For guidance on using specific components, please refer to our Technical Installation Details and Installation Guides. If there is any uncertainty, please seek expert advice.

The related documents mentioned above were accurate and up to date at the time of writing this guide. However, please note that information may have changed since then, and we recommend verifying any external sources for the most current information.

CodeMark
CMNZ30084



jsc.co.nz
TechHelp@jsc.co.nz | (09) 412 2812

TYPE
VERTICAL SHIPLAP WB - 20mm CAVITY FIX

NAME
RELATED DOCUMENTS

- TO BE READ IN CONJUNCTION WITH COMPLETE JSC VERTICLAD SYSTEM LITERATURE
- DETAILS MAY BE SUBJECT TO CHANGE WITHOUT NOTICE



SCAN IT FOR MORE
INFORMATION

DRAWING SCALE NTS	ISSUE DATE 11/02/2026
DRAWING NUMBER JSC 20CR VS04	VERSION 2.6

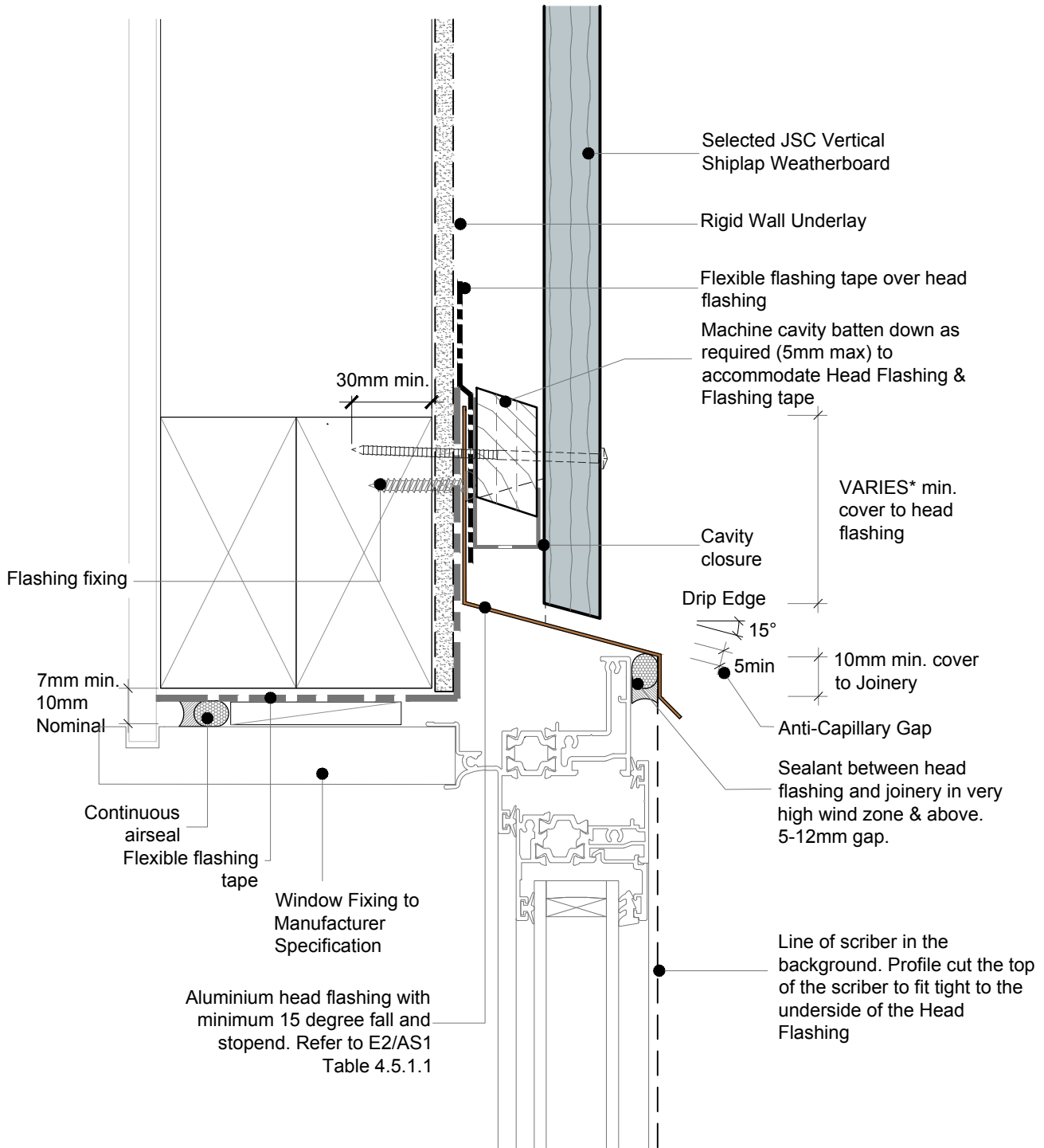

NOTE: In this situation, ensure a minimum penetration of 30mm into the timber frame due to the presence of multiple elements, including cavity batten, flashing tape, cavity closure, and head flashing.

*JSC recommends no hooks or hems. Therefore, the flashing upstand dimensions must be increased by 25 mm in accordance with E2/AS1, Section 4.4.3

• TO BE READ IN CONJUNCTION WITH COMPLETE JSC VERTICLAD SYSTEM LITERATURE

CodeMark
CMNZ30084



jsc.co.nz
TechHelp@jsc.co.nz | (09) 412 2812

TYPE
VERTICAL SHIPLAP WB - 20MM CAVITY FIX
NAME
Window Head Detail

• DETAILS MAY BE SUBJECT TO CHANGE WITHOUT NOTICE



SCAN IT FOR MORE INFORMATION

DRAWING SCALE 1:2 @ A4	ISSUE DATE 11/02/2026
DRAWING NUMBER JSC 20CR VS10	VERSION 2.6

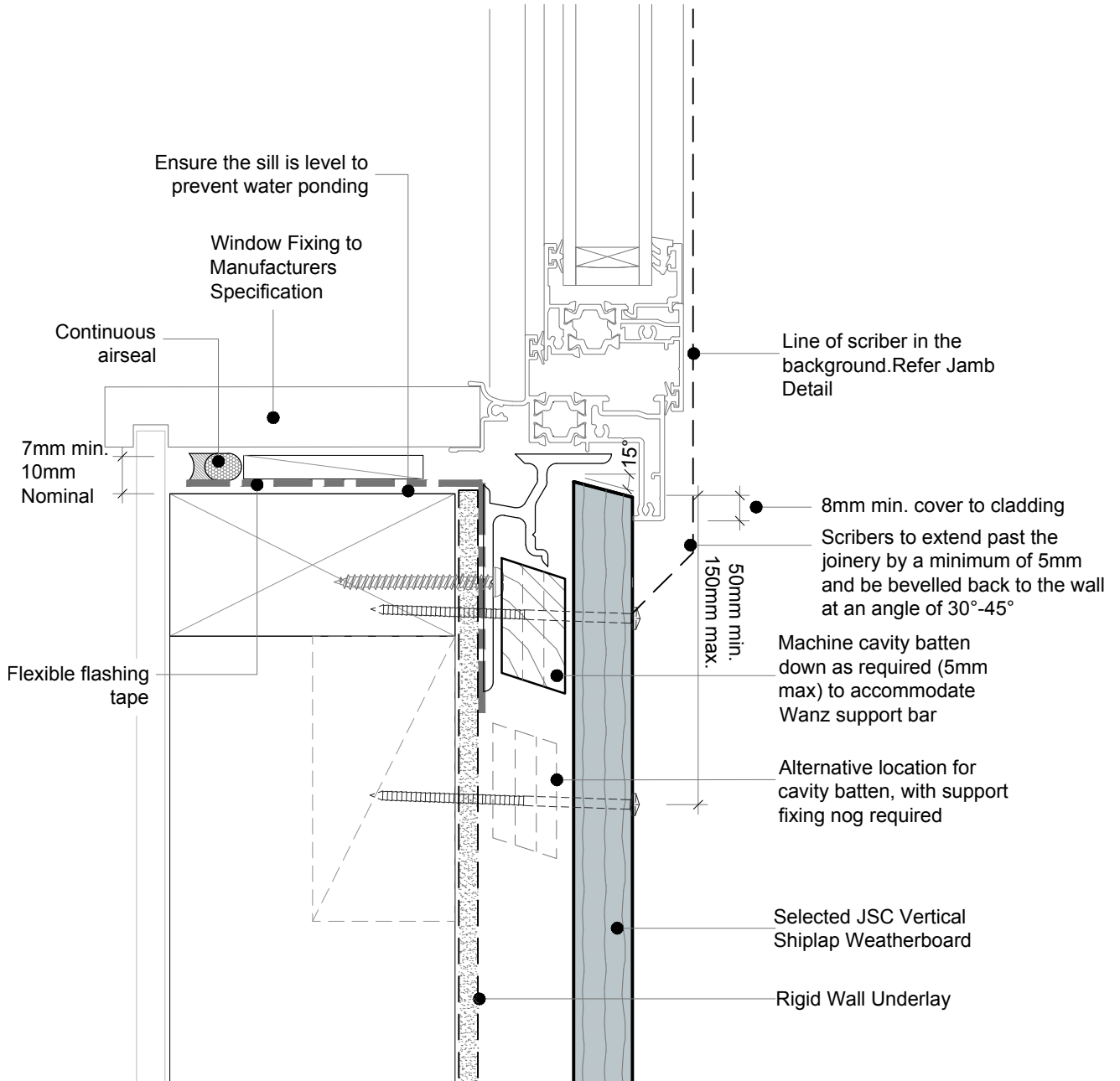

• TO BE READ IN CONJUNCTION WITH COMPLETE JSC VERTICLAD SYSTEM LITERATURE

CodeMark
CMNZ30084



jsc.co.nz
TechHelp@jsc.co.nz | (09) 412 2812

TYPE
VERTICAL SHIPLAP WB - 20MM CAVITY FIX

NAME
Window Sill Detail

• DETAILS MAY BE SUBJECT TO CHANGE WITHOUT NOTICE



SCAN IT FOR MORE INFORMATION

DRAWING SCALE 1:2 @ A4	ISSUE DATE 11/02/2026
DRAWING NUMBER JSC 20CR VS11	VERSION 2.6

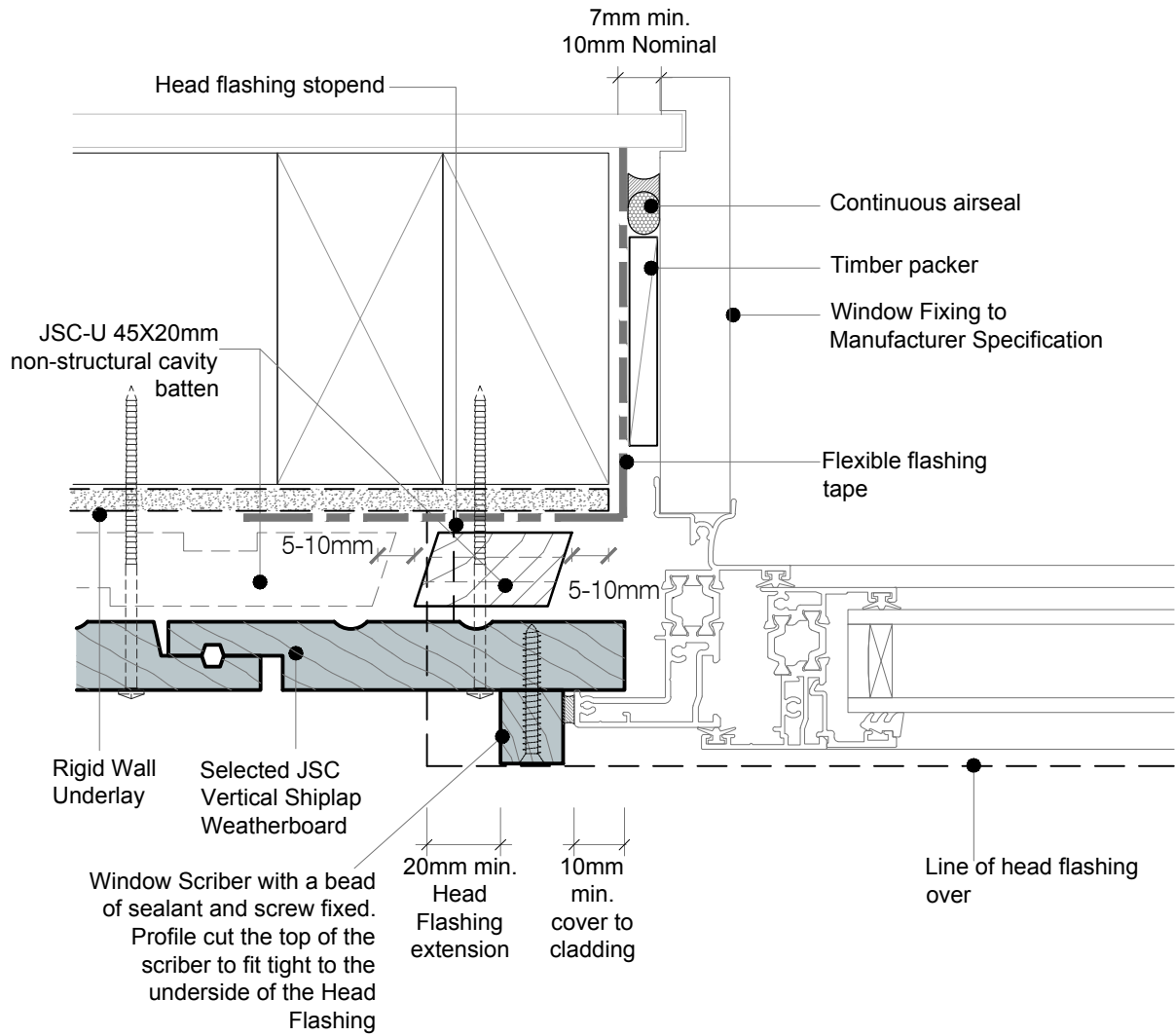

• TO BE READ IN CONJUNCTION WITH COMPLETE JSC VERTICLAD SYSTEM LITERATURE

CodeMark
CMNZ30084



jsc.co.nz
TechHelp@jsc.co.nz | (09) 412 2812

TYPE
VERTICAL SHIPLAP WB - 20MM CAVITY FIX

NAME
Window Jamb Detail - Scriber

• DETAILS MAY BE SUBJECT TO CHANGE WITHOUT NOTICE



SCAN IT FOR MORE INFORMATION

DRAWING SCALE 1:2 @ A4	ISSUE DATE 11/02/2026
DRAWING NUMBER JSC 20CR VS12	VERSION 2.6

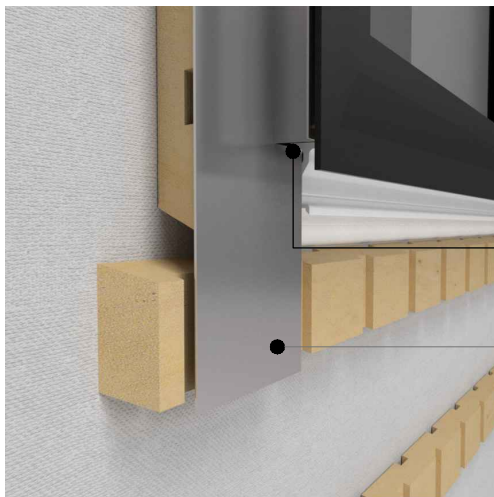
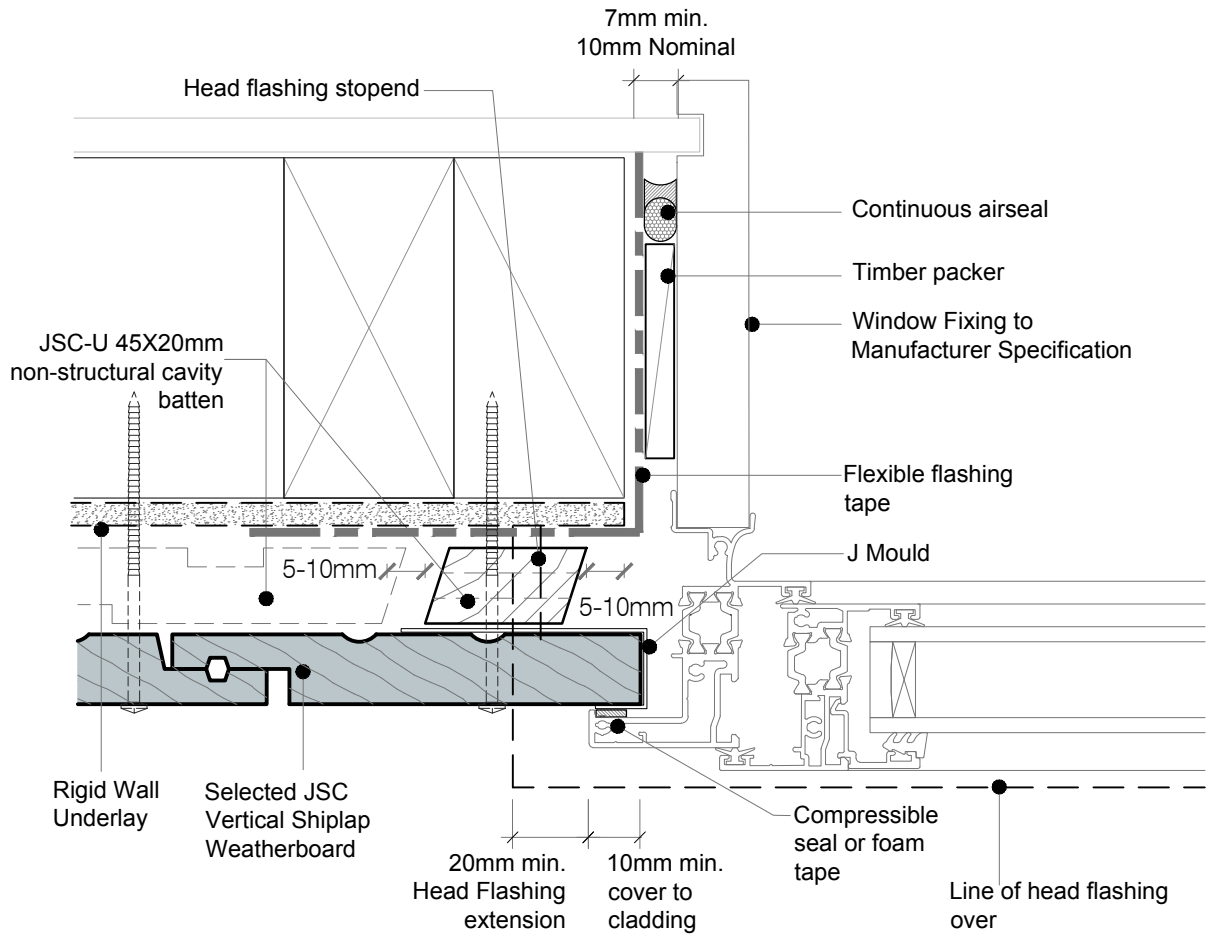

Cut and fold J Mould

J Mould to extend past sill cavity batten

NOTE : No Scriber Option :

The Aluminium Joinery must sit hard against the back of the joinery flange and the timber weatherboards with a seal or foam tape in between.

• TO BE READ IN CONJUNCTION WITH COMPLETE JSC VERTICLAD SYSTEM LITERATURE

CodeMark
CMNZ30084



jsc.co.nz
TechHelp@jsc.co.nz | (09) 412 2812

TYPE
VERTICAL SHIPLAP WB - 20MM CAVITY FIX

NAME
Window Jamb Detail - No Scriber

• DETAILS MAY BE SUBJECT TO CHANGE WITHOUT NOTICE



SCAN IT FOR MORE INFORMATION

DRAWING SCALE 1:2 @ A4	ISSUE DATE 11/02/2026
DRAWING NUMBER JSC 20CR VS13	VERSION 2.6

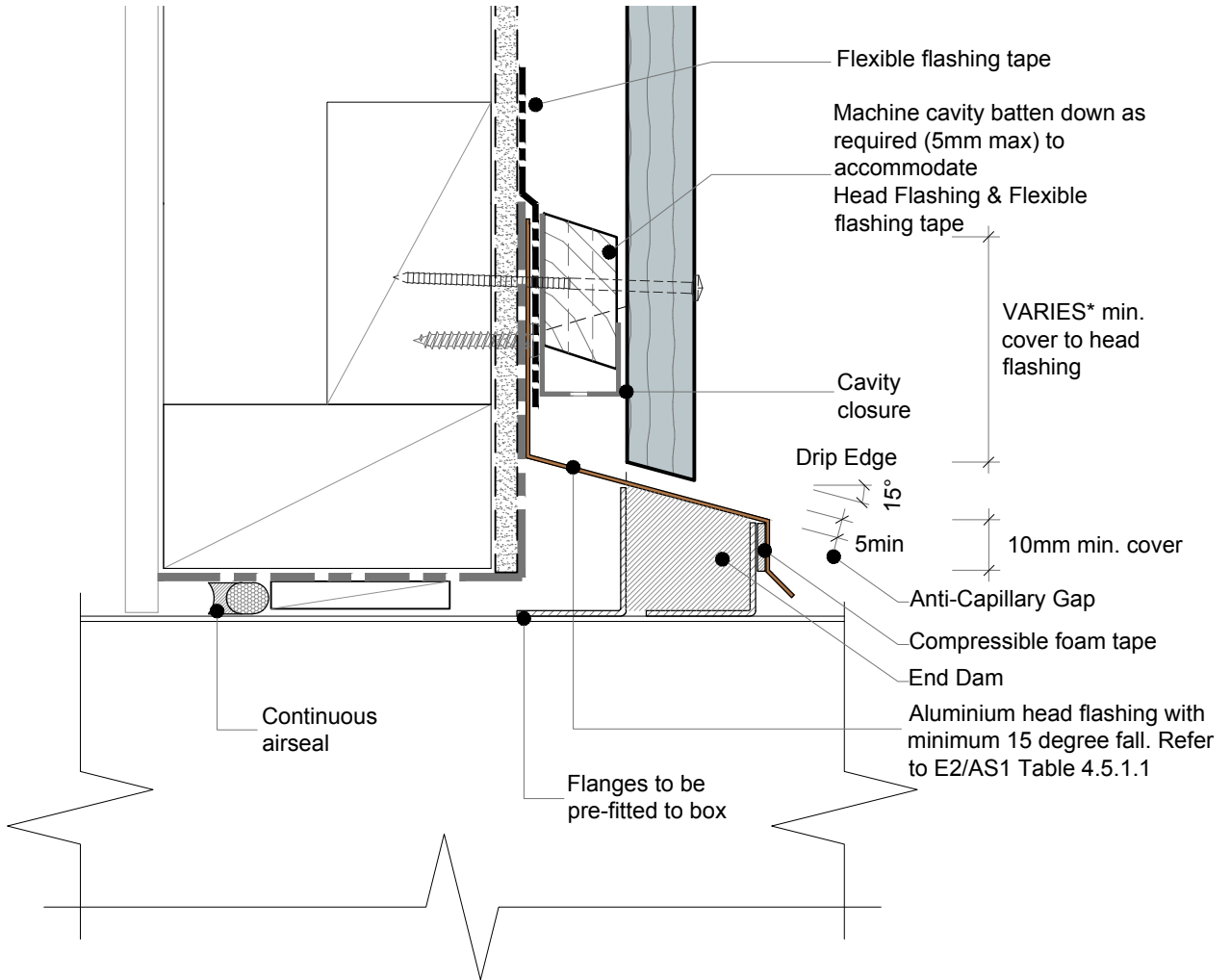

*JSC recommends no hooks or hems. Therefore, the flashing upstand dimensions must be increased by 25 mm in accordance with E2/AS1, Section 4.4.3

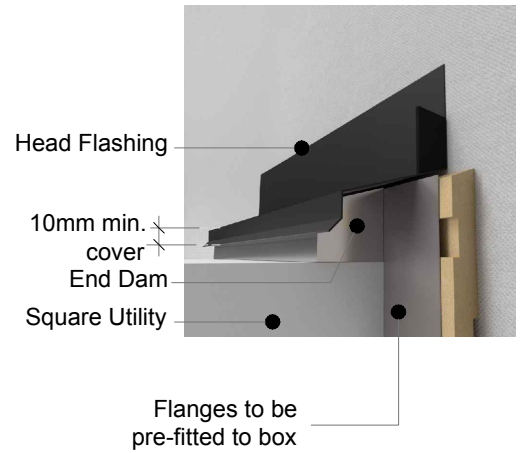
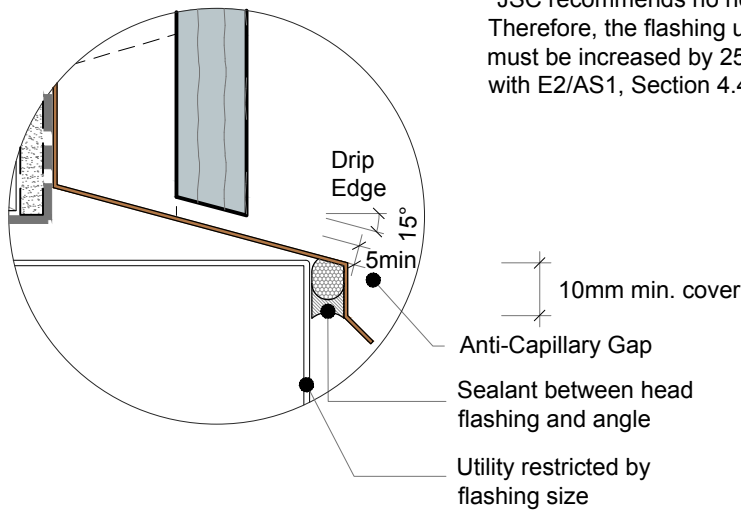

• TO BE READ IN CONJUNCTION WITH COMPLETE JSC VERTICLAD SYSTEM LITERATURE

CodeMark
CMNZ30084



DRAWING SCALE 1:2 @ A4	ISSUE DATE 11/02/2026
DRAWING NUMBER JSC 20CR VS30	VERSION 2.6

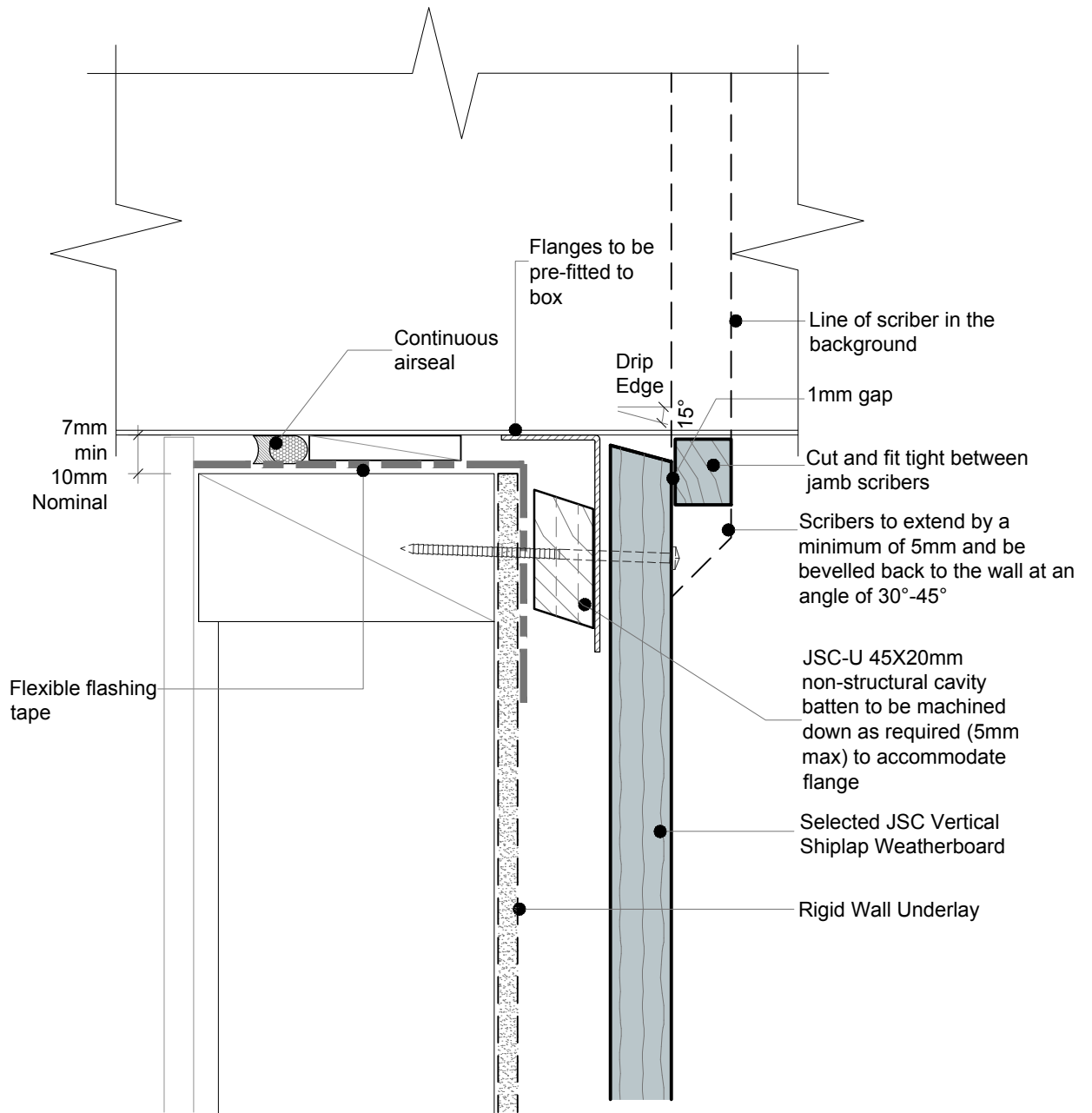

• TO BE READ IN CONJUNCTION WITH COMPLETE JSC VERTICLAD SYSTEM LITERATURE

CodeMark
CMNZ30084

JSC PREMIUM ARCHITECTURAL
& BUILDING SOLUTIONS

jsc.co.nz
TechHelp@jsc.co.nz | (09) 412 2812

TYPE
VERTICAL SHIPLAP WB - 20MM CAVITY FIX

NAME
Square Utility Sill Detail

• DETAILS MAY BE SUBJECT TO CHANGE WITHOUT NOTICE



SCAN IT FOR MORE
INFORMATION

DRAWING SCALE 1:2 @ A4	ISSUE DATE 11/02/2026
DRAWING NUMBER JSC 20CR VS31	VERSION 2.6

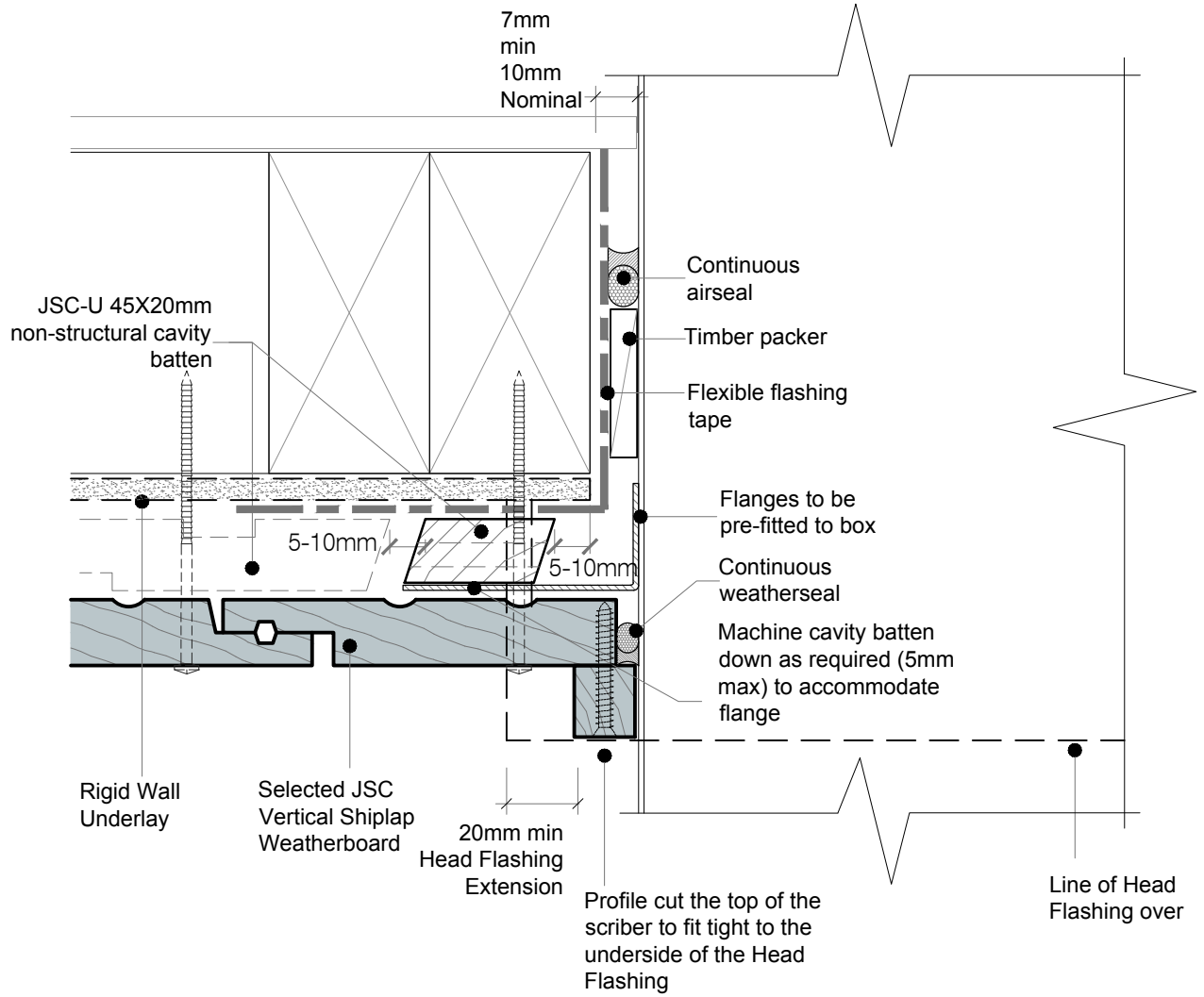

• TO BE READ IN CONJUNCTION WITH COMPLETE JSC VERTICLAD SYSTEM LITERATURE

CodeMark
CMNZ30084



jsc.co.nz
TechHelp@jsc.co.nz | (09) 412 2812

TYPE
VERTICAL SHIPLAP WB - 20MM CAVITY FIX

NAME
Square Utility Jamb Detail

• DETAILS MAY BE SUBJECT TO CHANGE WITHOUT NOTICE



SCAN IT FOR MORE INFORMATION

DRAWING SCALE 1:2 @ A4	ISSUE DATE 11/02/2026
DRAWING NUMBER JSC 20CR VS32	VERSION 2.6

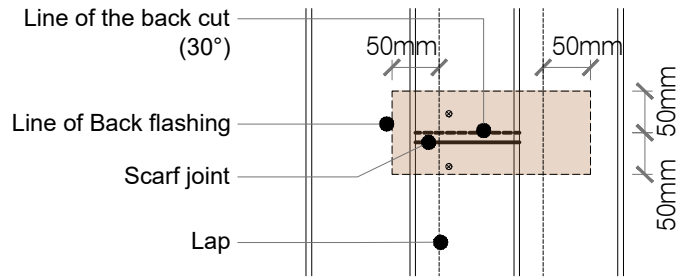

FRONT VIEW

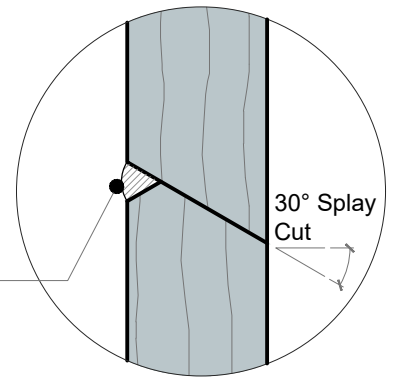
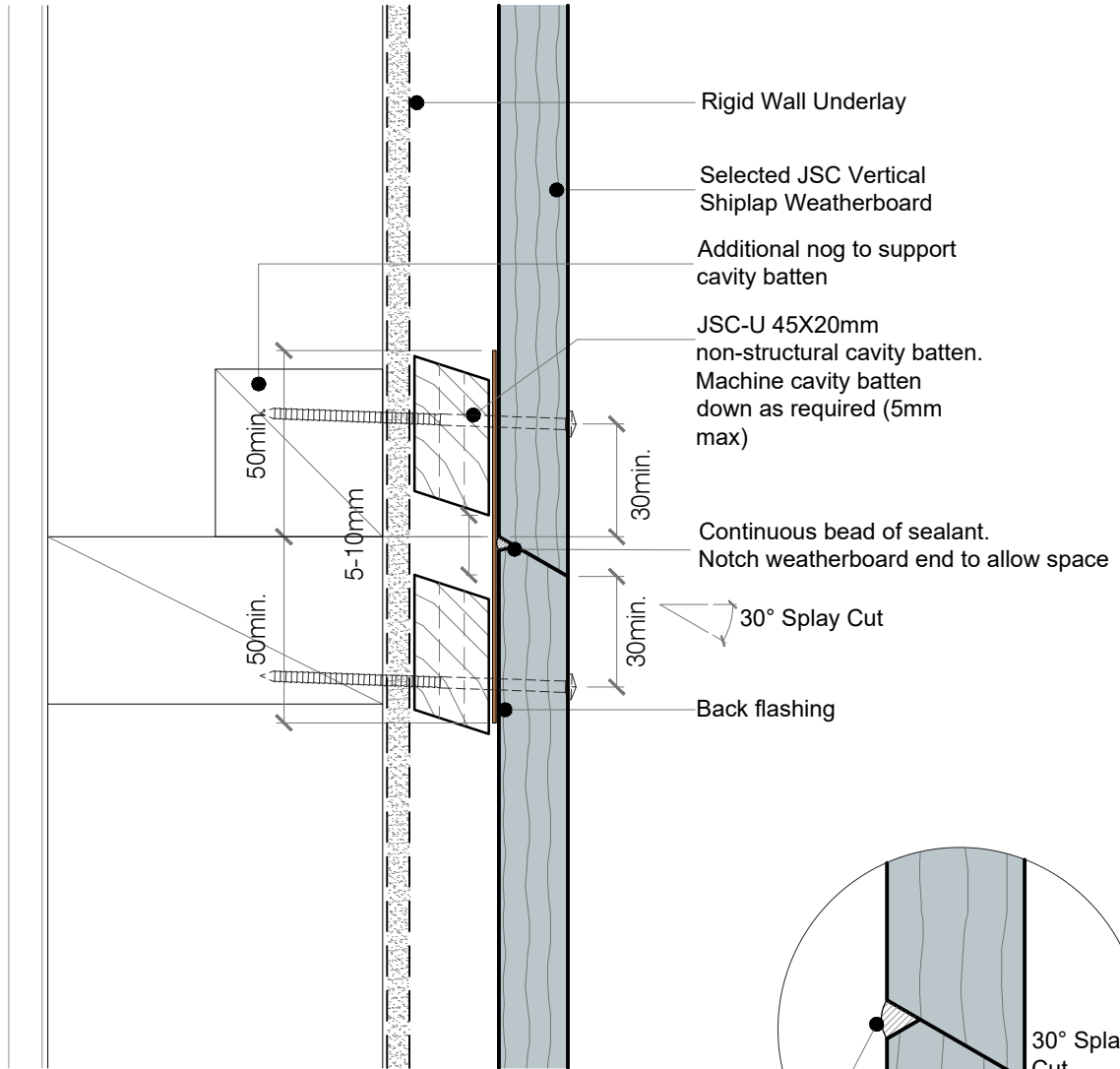

NOTES:

- This detail is not to be used on Paint Finished weatherboards.
- Not to be used on Pine weatherboards.

• TO BE READ IN CONJUNCTION WITH COMPLETE JSC VERTICLAD SYSTEM LITERATURE

CodeMark
 CMNZ30084



DRAWING SCALE 1:2 @ A4	ISSUE DATE 11/02/2026
DRAWING NUMBER JSC 20CR VS40	VERSION 2.6

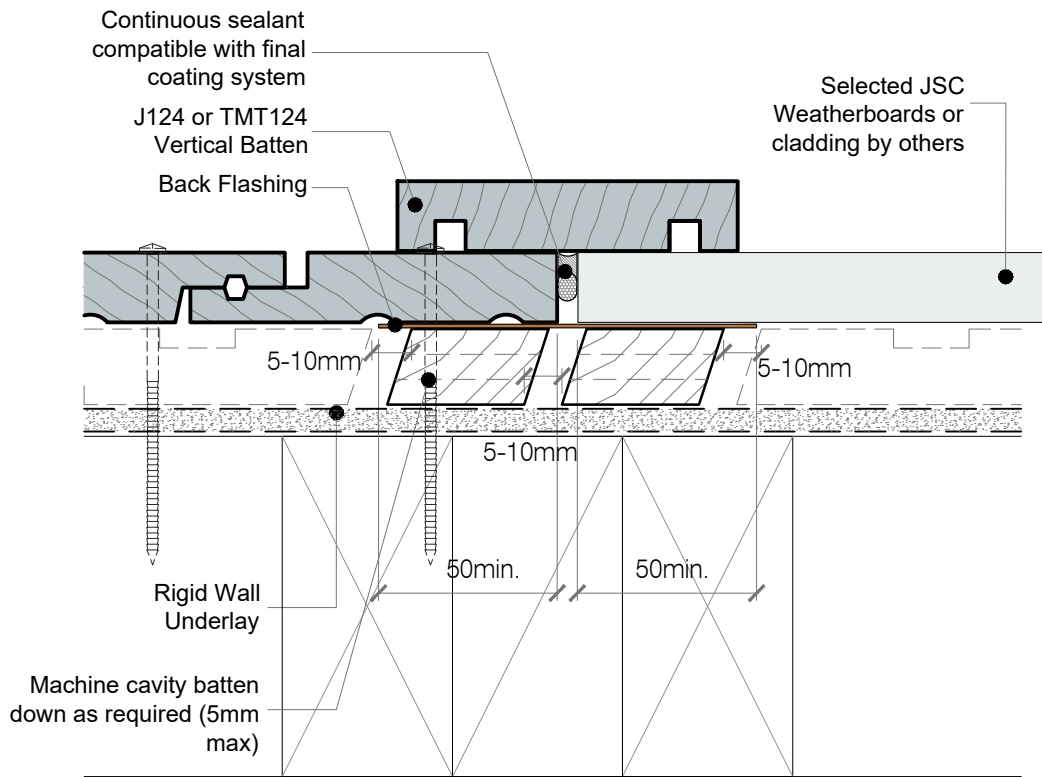

• TO BE READ IN CONJUNCTION WITH COMPLETE JSC VERTICLAD SYSTEM LITERATURE

CodeMark
 CMNZ30084



jsc.co.nz
 TechHelp@jsc.co.nz | (09) 412 2812

TYPE
 VERTICAL SHIPLAP WB - 20MM CAVITY FIX

NAME
 Vertical Control Joint

• DETAILS MAY BE SUBJECT TO CHANGE WITHOUT NOTICE



SCAN IT FOR MORE INFORMATION

DRAWING SCALE 1:2 @ A4	ISSUE DATE 11/02/2026
DRAWING NUMBER JSC 20CR VS41	VERSION 2.6

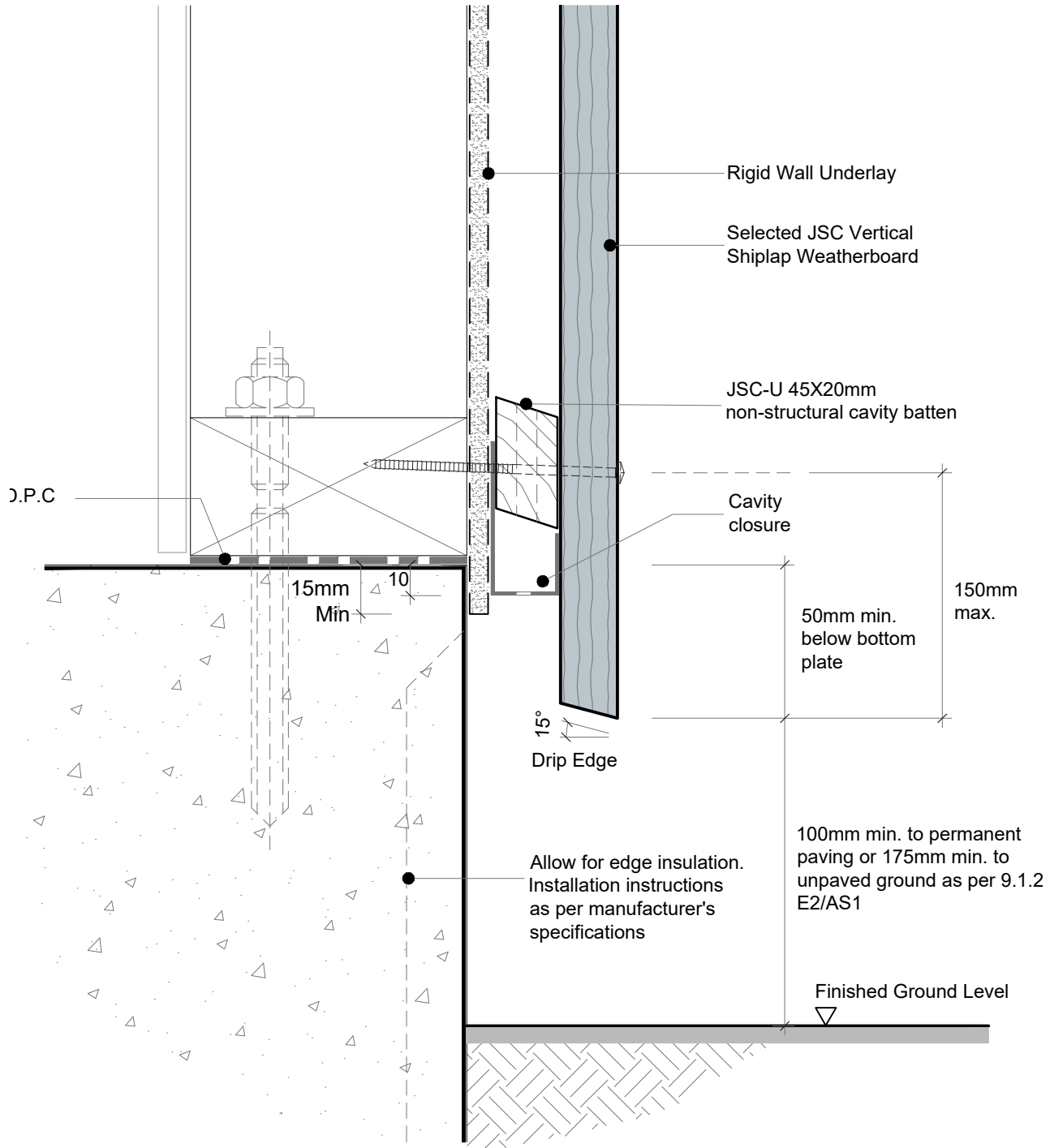

• TO BE READ IN CONJUNCTION WITH COMPLETE JSC VERTICLAD SYSTEM LITERATURE

CodeMark
 CMNZ30084



jsc.co.nz
 TechHelp@jsc.co.nz | (09) 412 2812

TYPE
 VERTICAL SHIPLAP WB - 20MM CAVITY FIX

NAME
 Base of Wall, Concrete

• DETAILS MAY BE SUBJECT TO CHANGE WITHOUT NOTICE



SCAN IT FOR MORE INFORMATION

DRAWING SCALE 1:2 @ A4	ISSUE DATE 11/02/2026
DRAWING NUMBER JSC 20CR VS42	VERSION 2.6

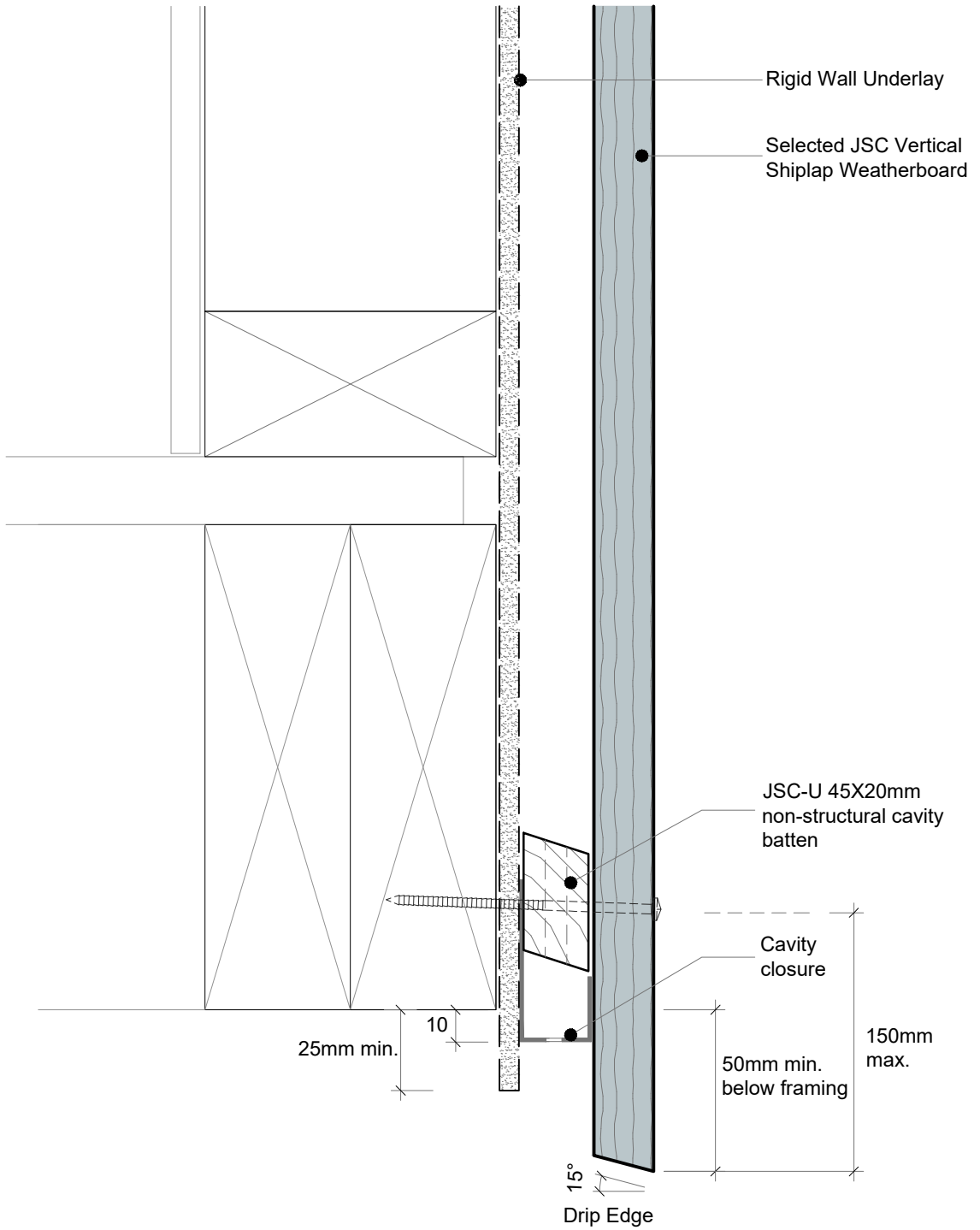

• TO BE READ IN CONJUNCTION WITH COMPLETE JSC VERTICLAD SYSTEM LITERATURE

CodeMark
 CMNZ30084



jsc.co.nz
 TechHelp@jsc.co.nz | (09) 412 2812

TYPE
 VERTICAL SHIPLAP WB - 20MM CAVITY FIX

NAME
 Base of Wall, Timber

• DETAILS MAY BE SUBJECT TO CHANGE WITHOUT NOTICE



SCAN IT FOR MORE INFORMATION

DRAWING SCALE 1:2 @ A4	ISSUE DATE 11/02/2026
DRAWING NUMBER JSC 20CR VS43	VERSION 2.6

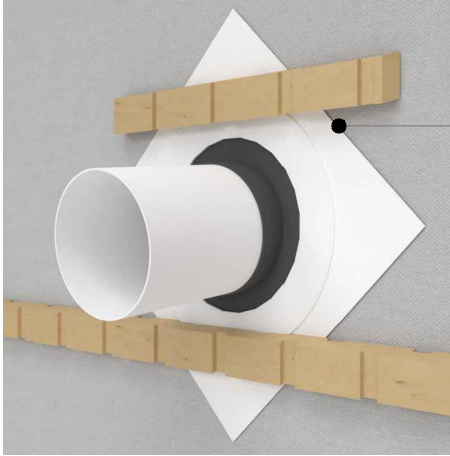

Proprietary self adhesive collar at 45°



Continuous weather seal around pipe



Sealant in the negative(s) above pipe penetration

Flange plate over pipe, sealed around pipe and top half of flange. Refer to Figure 9.1.8.3A E2/AS1

No sealant to drain

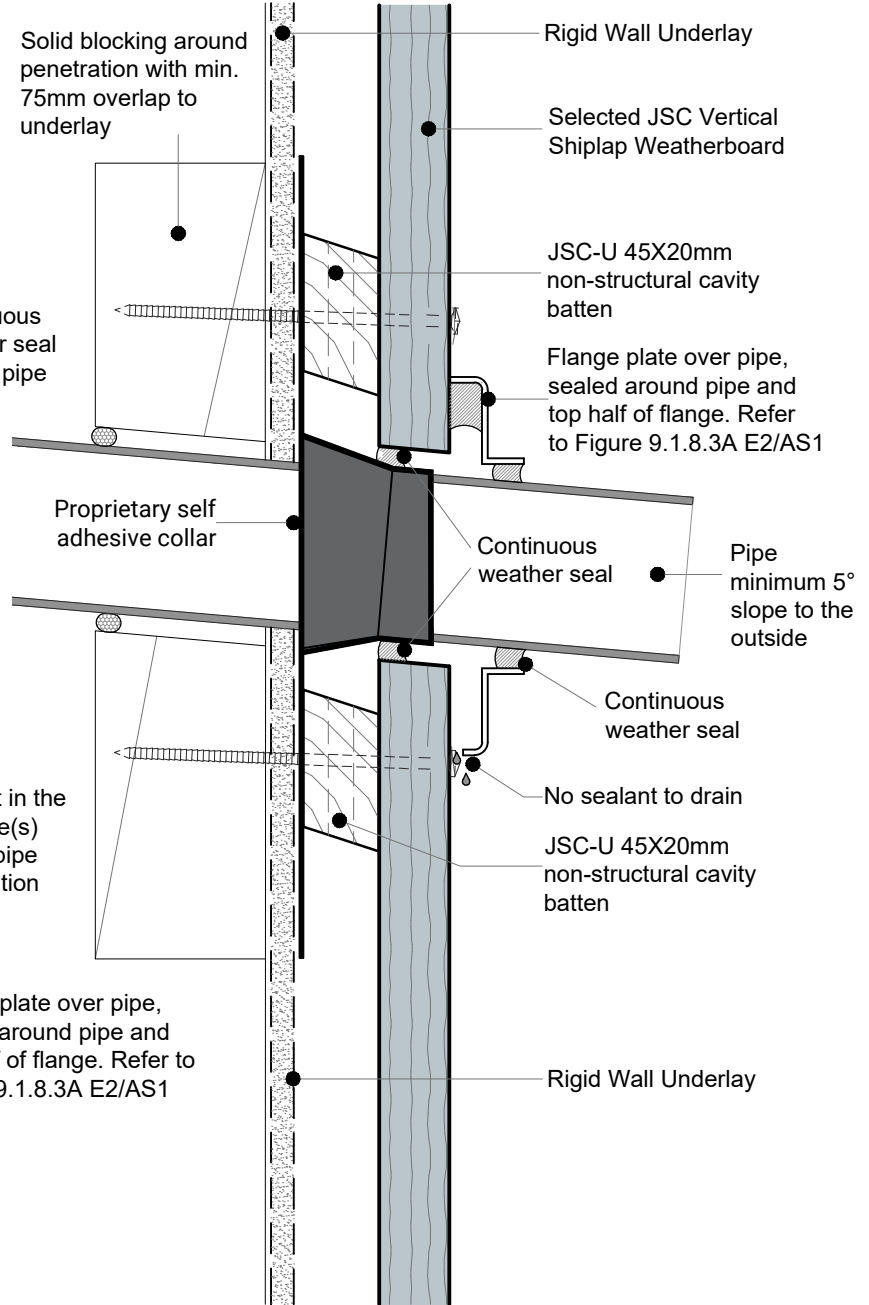

• TO BE READ IN CONJUNCTION WITH COMPLETE JSC VERTICLAD SYSTEM LITERATURE

CodeMark
 CMNZ30084



jsc.co.nz
 TechHelp@jsc.co.nz | (09) 412 2812

TYPE
 VERTICAL SHIPLAP WB - 20MM CAVITY FIX

NAME
 Pipe Penetration

• DETAILS MAY BE SUBJECT TO CHANGE WITHOUT NOTICE



SCAN IT FOR MORE INFORMATION

DRAWING SCALE 1:2 @ A4	ISSUE DATE 11/02/2026
DRAWING NUMBER JSC 20CR VS44	VERSION 2.6

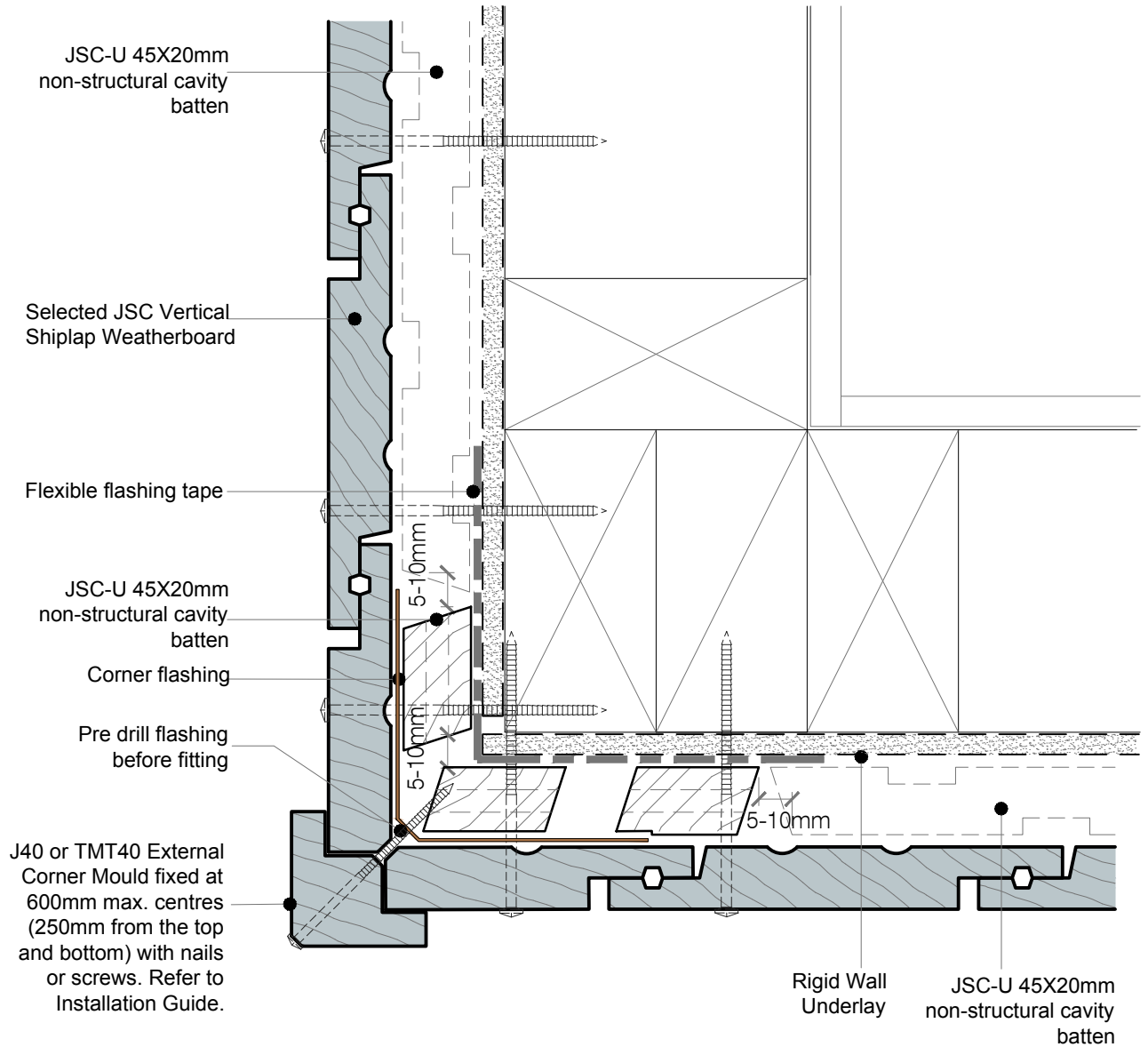

NOTES:

- Machine cavity battens down as required (5mm max) to accommodate corner flashing.
- Cut horizontal and vertical cavity battens on a 20-30° angle, sloping away from the framing.
- For Very High (VH) and Extra High (EH) wind zones, a solid batten (non-castellated) is required down one side of a significant external corner (change in elevation) to provide pressure isolation between elevations.

• TO BE READ IN CONJUNCTION WITH COMPLETE JSC VERTICLAD SYSTEM LITERATURE

CodeMark
CMNZ30084



jsc.co.nz
TechHelp@jsc.co.nz | (09) 412 2812

TYPE
VERTICAL SHIPLAP WB - 20MM CAVITY FIX

NAME
External Corner - J40

• DETAILS MAY BE SUBJECT TO CHANGE WITHOUT NOTICE



SCAN IT FOR MORE INFORMATION

DRAWING SCALE 1:2 @ A4	ISSUE DATE 11/02/2026
DRAWING NUMBER JSC 20CR VS50	VERSION 2.6

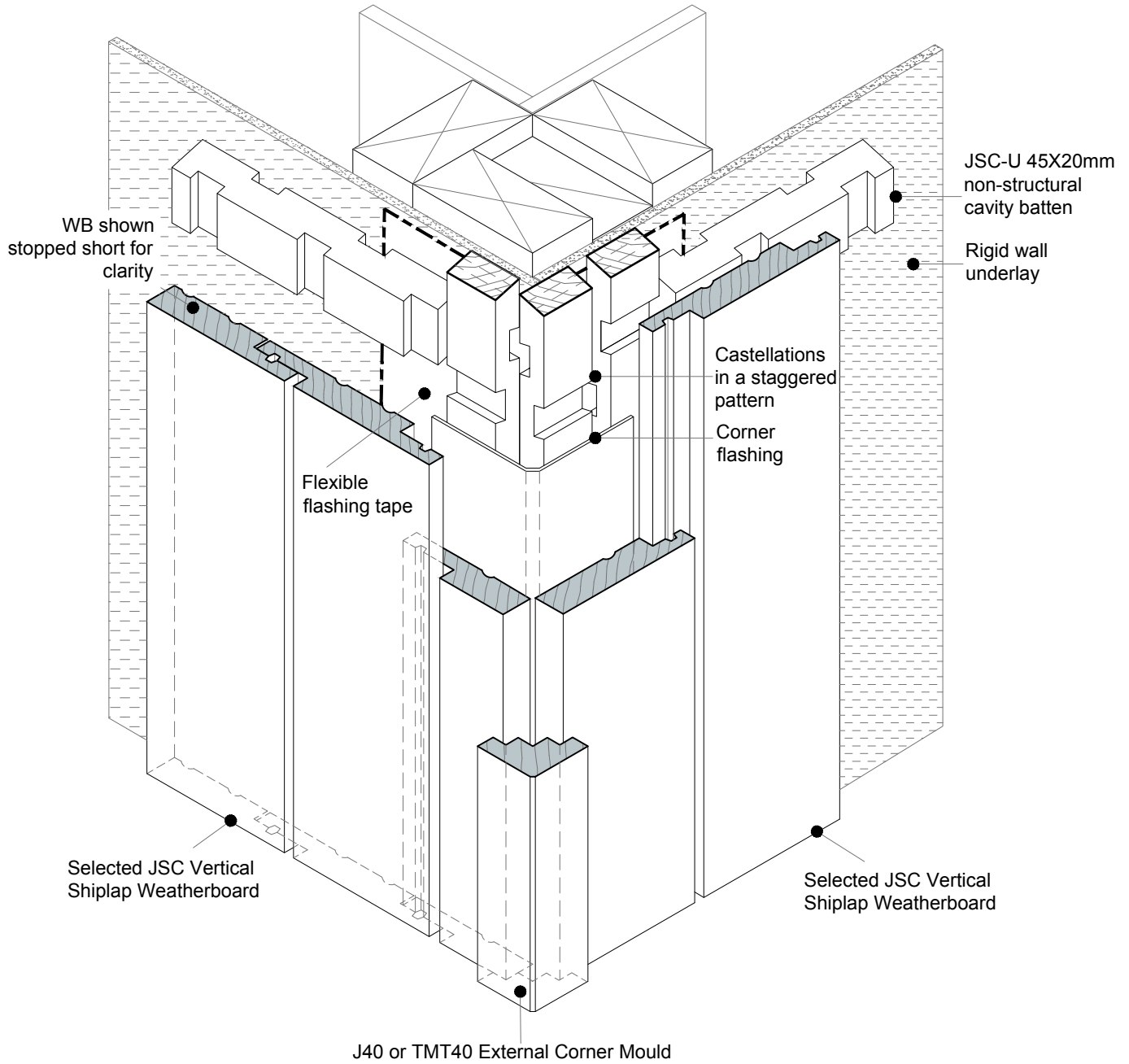

• TO BE READ IN CONJUNCTION WITH COMPLETE JSC VERTICLAD SYSTEM LITERATURE

CodeMark
CMNZ30084



jsc.co.nz
TechHelp@jsc.co.nz | (09) 412 2812

TYPE
VERTICAL SHIPLAP WB - 20MM CAVITY FIX

NAME
3D - External Corner - J40

• DETAILS MAY BE SUBJECT TO CHANGE WITHOUT NOTICE



SCAN IT FOR MORE INFORMATION

DRAWING SCALE 1:2 @ A4	ISSUE DATE 11/02/2026
DRAWING NUMBER JSC 20CR VS51	VERSION 2.6

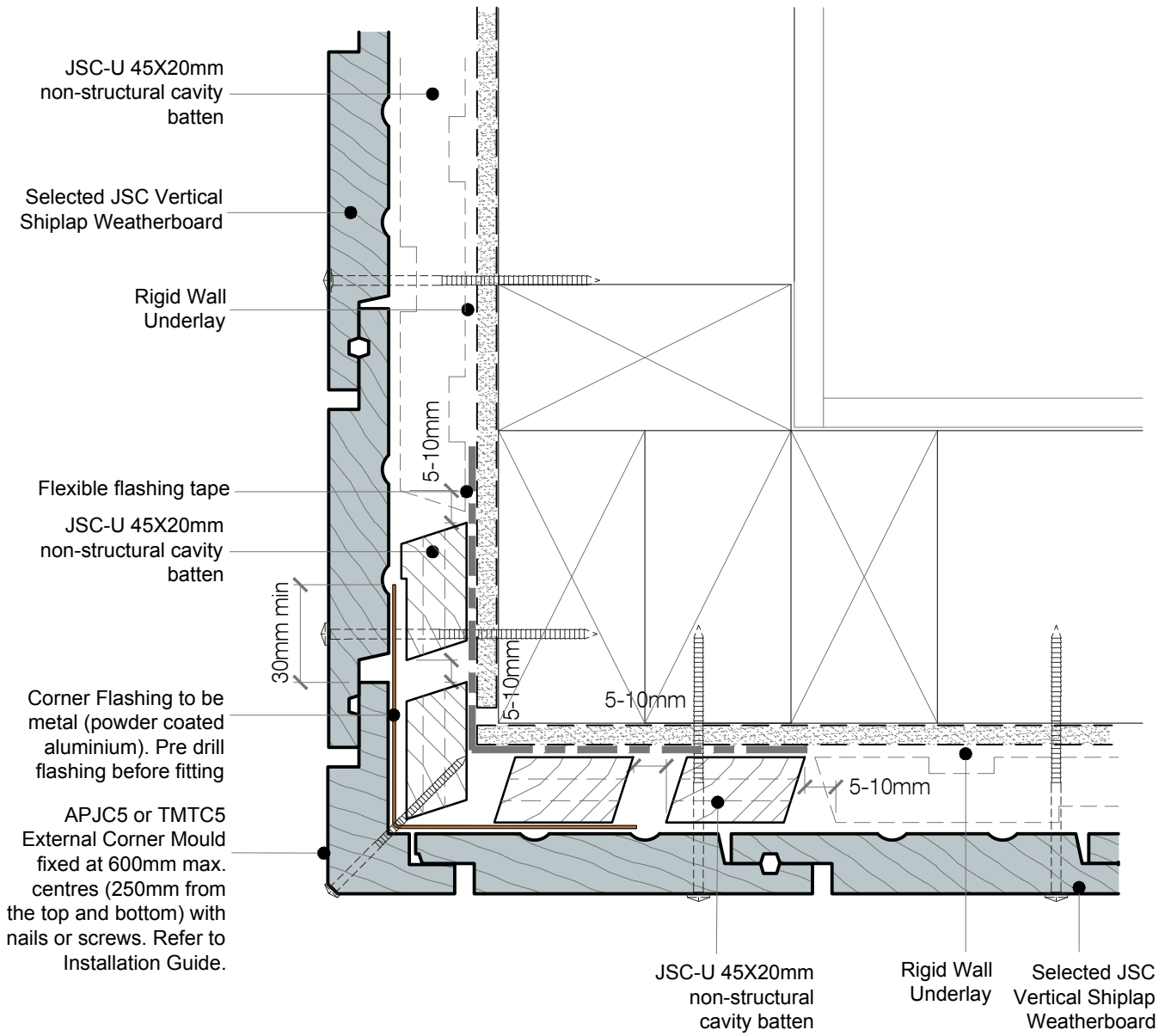

NOTES:

- Machine cavity battens down as required (5mm max) to accommodate corner flashing.
- Cut horizontal and vertical cavity battens on a 20-30° angle, sloping away from the framing.
- For Very High (VH) and Extra High (EH) wind zones, a solid batten (non-castellated) is required down one side of a significant external corner (change in elevation) to provide pressure isolation between elevations.

• TO BE READ IN CONJUNCTION WITH COMPLETE JSC VERTICLAD SYSTEM LITERATURE

CodeMark
CMNZ30084



jsc.co.nz
TechHelp@jsc.co.nz | (09) 412 2812

TYPE
VERTICAL SHIPLAP WB - 20MM CAVITY FIX
NAME
External Corner - APJC5

• DETAILS MAY BE SUBJECT TO CHANGE WITHOUT NOTICE



SCAN IT FOR MORE INFORMATION

DRAWING SCALE 1:2 @ A4	ISSUE DATE 11/02/2026
DRAWING NUMBER JSC 20CR VS52	VERSION 2.6

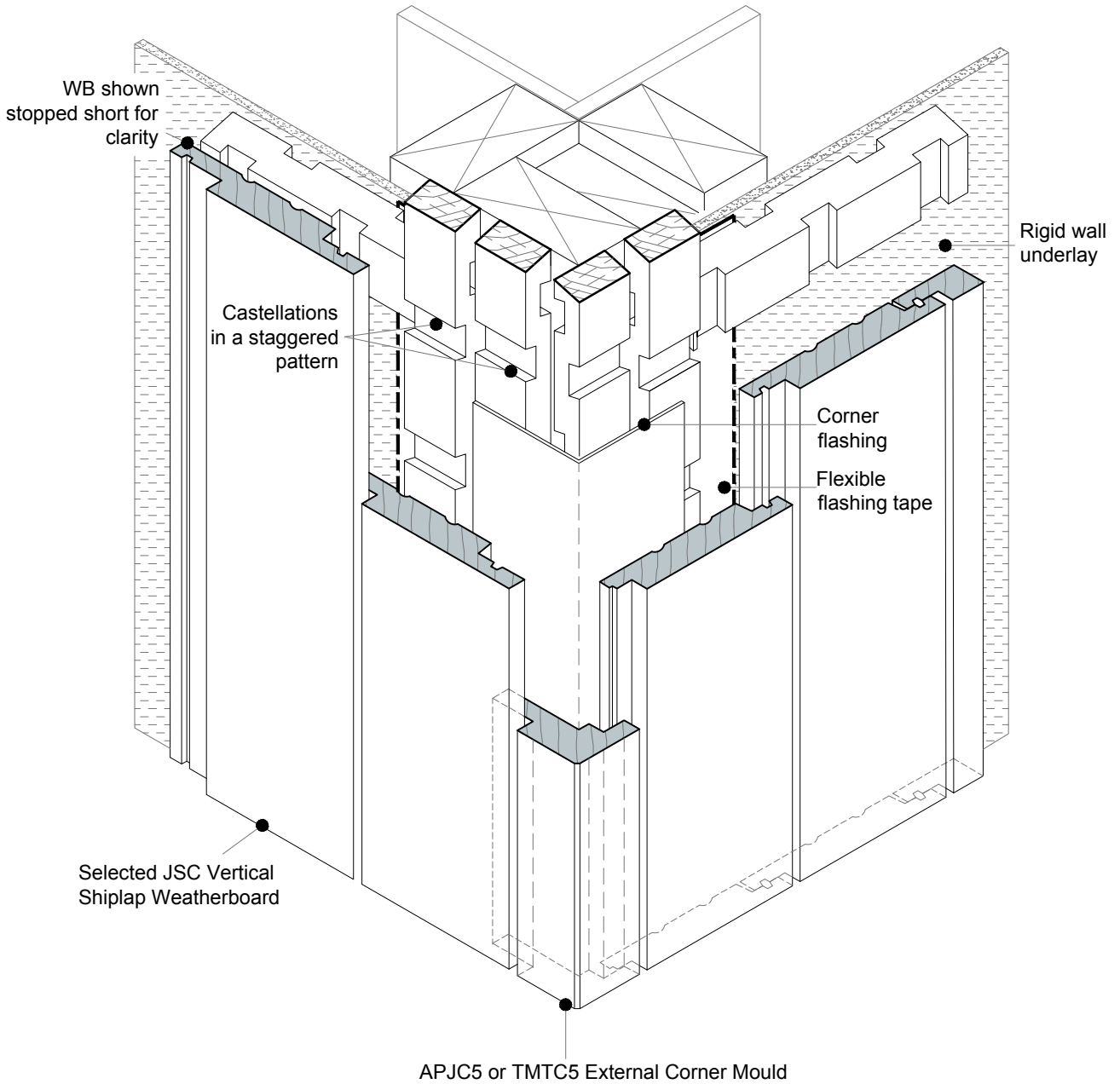

DETAIL NOTE :

For Very High (VH) and Extra High (EH) wind zones (as defined NZS 3604), a solid batten (non castellated) is required down one side of a significant external corner (change in elevation) to provide pressure isolation between elevations.

• TO BE READ IN CONJUNCTION WITH COMPLETE JSC VERTICLAD SYSTEM LITERATURE

CodeMark
CMNZ30084



DRAWING SCALE 1:2 @ A4	ISSUE DATE 11/02/2026
DRAWING NUMBER JSC 20CR VS53	VERSION 2.6

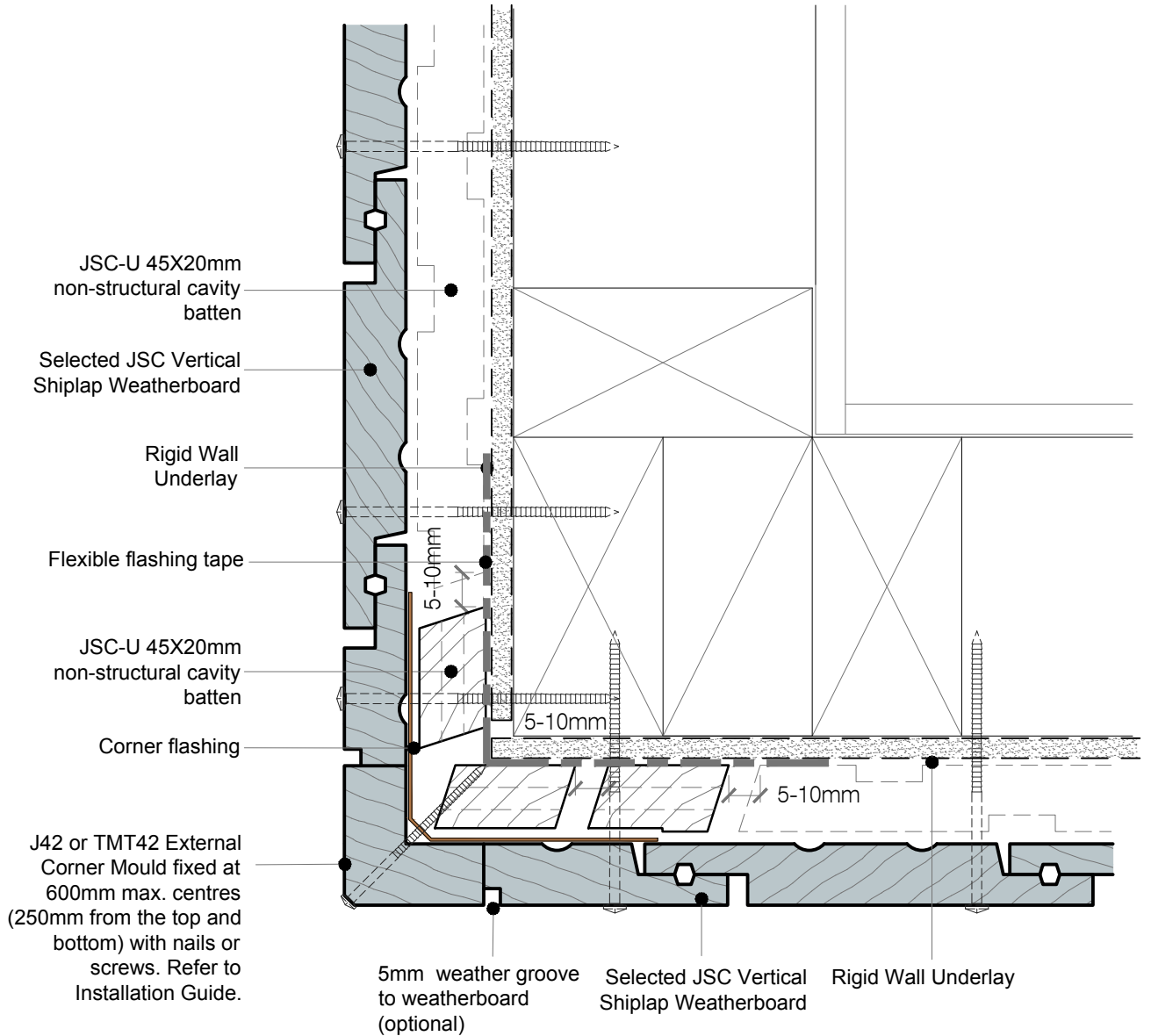

NOTES:

- Machine cavity battens down as required (5mm max) to accommodate corner flashing.
- Cut horizontal and vertical cavity battens on a 20-30° angle, sloping away from the framing.
- For Very High (VH) and Extra High (EH) wind zones, a solid batten (non-castellated) is required down one side of a significant external corner (change in elevation) to provide pressure isolation between elevations.
- JSC recommends this detail to be used for paint finished weatherboards.

• TO BE READ IN CONJUNCTION WITH COMPLETE JSC VERTICLAD SYSTEM LITERATURE

CodeMark
CMNZ30084



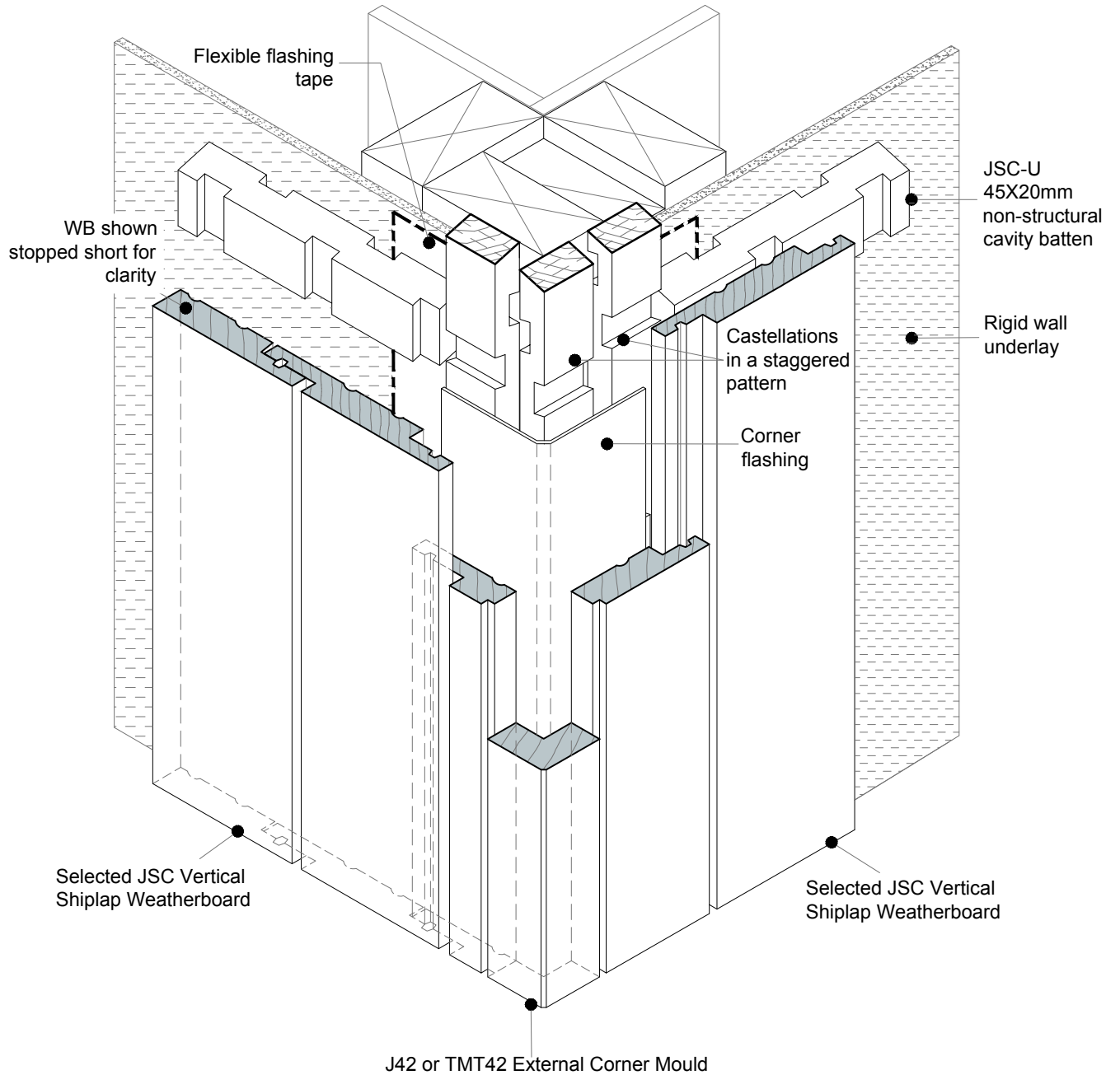

DETAIL NOTE :

- For Very High (VH) and Extra High (EH) wind zones (as defined NZS 3604), a solid batten (non castellated) is required down one side of a significant external corner (change in elevation) to provide pressure isolation between elevations.
- JSC recommends this detail to be used for paint finished weatherboards.

• TO BE READ IN CONJUNCTION WITH COMPLETE JSC VERTICLAD SYSTEM LITERATURE

CodeMark
CMNZ30084



DRAWING SCALE 1:2 @ A4	ISSUE DATE 11/02/2026
DRAWING NUMBER JSC 20CR VS55	VERSION 2.6

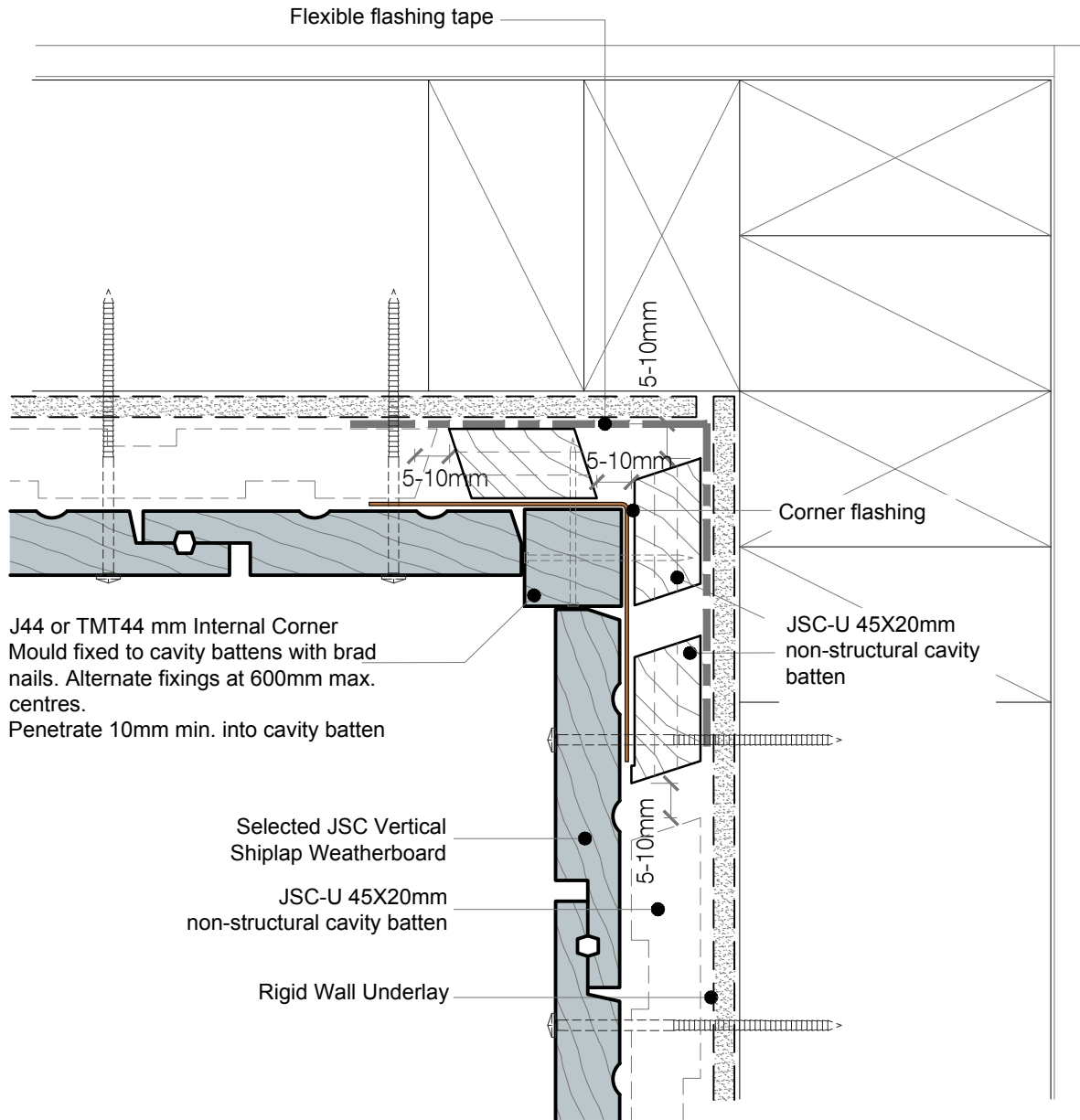

NOTES:

- Machine cavity battens down as required (5mm max) to accommodate corner flashing.
- Cut horizontal and vertical cavity battens on a 20-30° angle, sloping away from the framing.

• TO BE READ IN CONJUNCTION WITH COMPLETE JSC VERTICLAD SYSTEM LITERATURE

CodeMark
CMNZ30084

JSC PREMIUM ARCHITECTURAL & BUILDING SOLUTIONS

jsc.co.nz
TechHelp@jsc.co.nz | (09) 412 2812

TYPE
VERTICAL SHIPLAP WB - 20MM CAVITY FIX
NAME
Internal Corner - J44

• DETAILS MAY BE SUBJECT TO CHANGE WITHOUT NOTICE



SCAN IT FOR MORE INFORMATION

DRAWING SCALE 1:2 @ A4	ISSUE DATE 11/02/2026
DRAWING NUMBER JSC 20CR VS60	VERSION 2.6

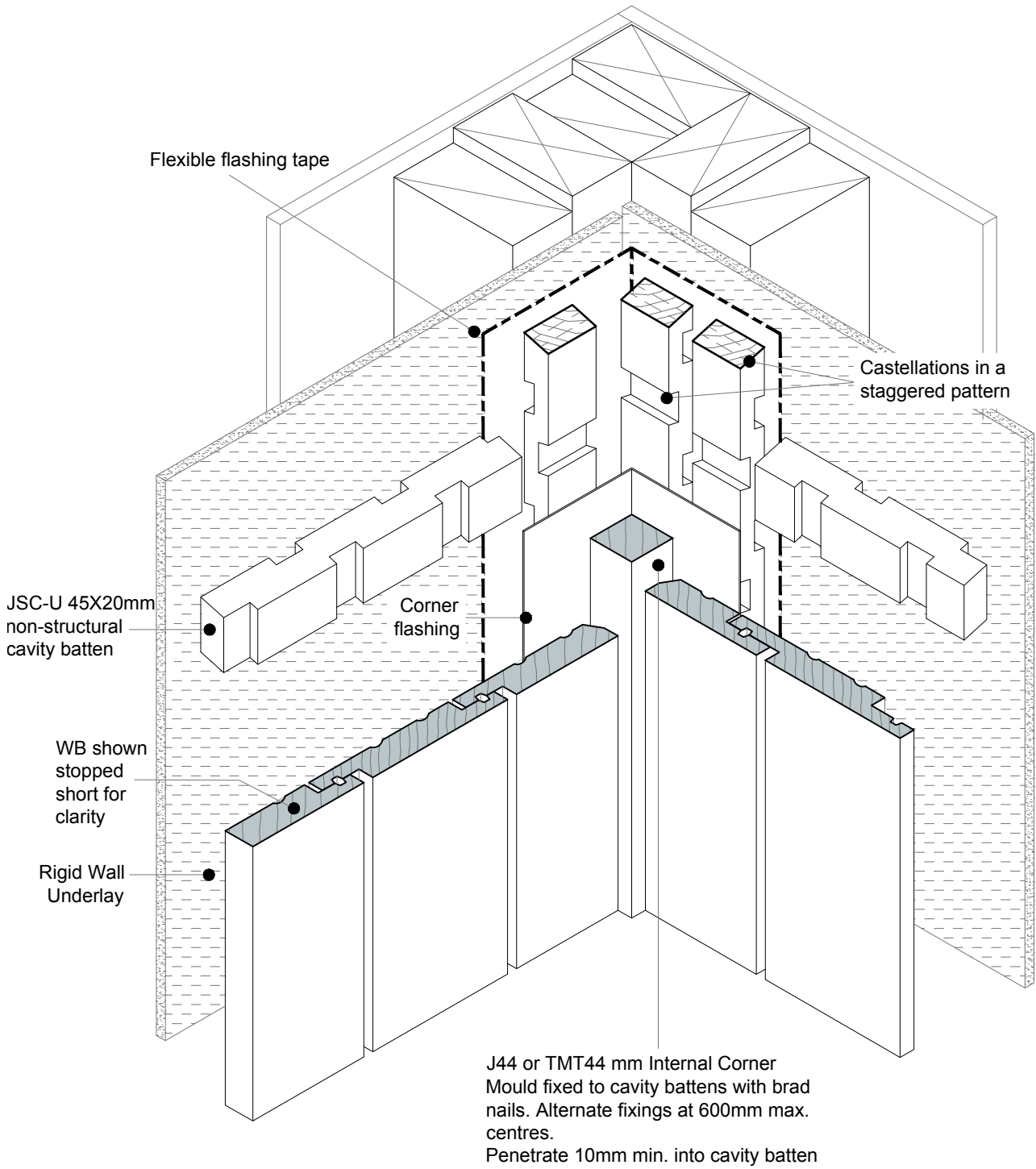

J44 or TMT44 mm Internal Corner Mould fixed to cavity battens with brad nails. Alternate fixings at 600mm max. centres. Penetrate 10mm min. into cavity batten

• TO BE READ IN CONJUNCTION WITH COMPLETE JSC VERTICLAD SYSTEM LITERATURE

CodeMark
CMNZ30084



jsc.co.nz
TechHelp@jsc.co.nz | (09) 412 2812

TYPE
VERTICAL SHIPLAP WB - 20MM CAVITY FIX

NAME
3D - Internal Corner - J44

• DETAILS MAY BE SUBJECT TO CHANGE WITHOUT NOTICE



SCAN IT FOR MORE INFORMATION

DRAWING SCALE 1:2 @ A4	ISSUE DATE 11/02/2026
DRAWING NUMBER JSC 20CR VS61	VERSION 2.6

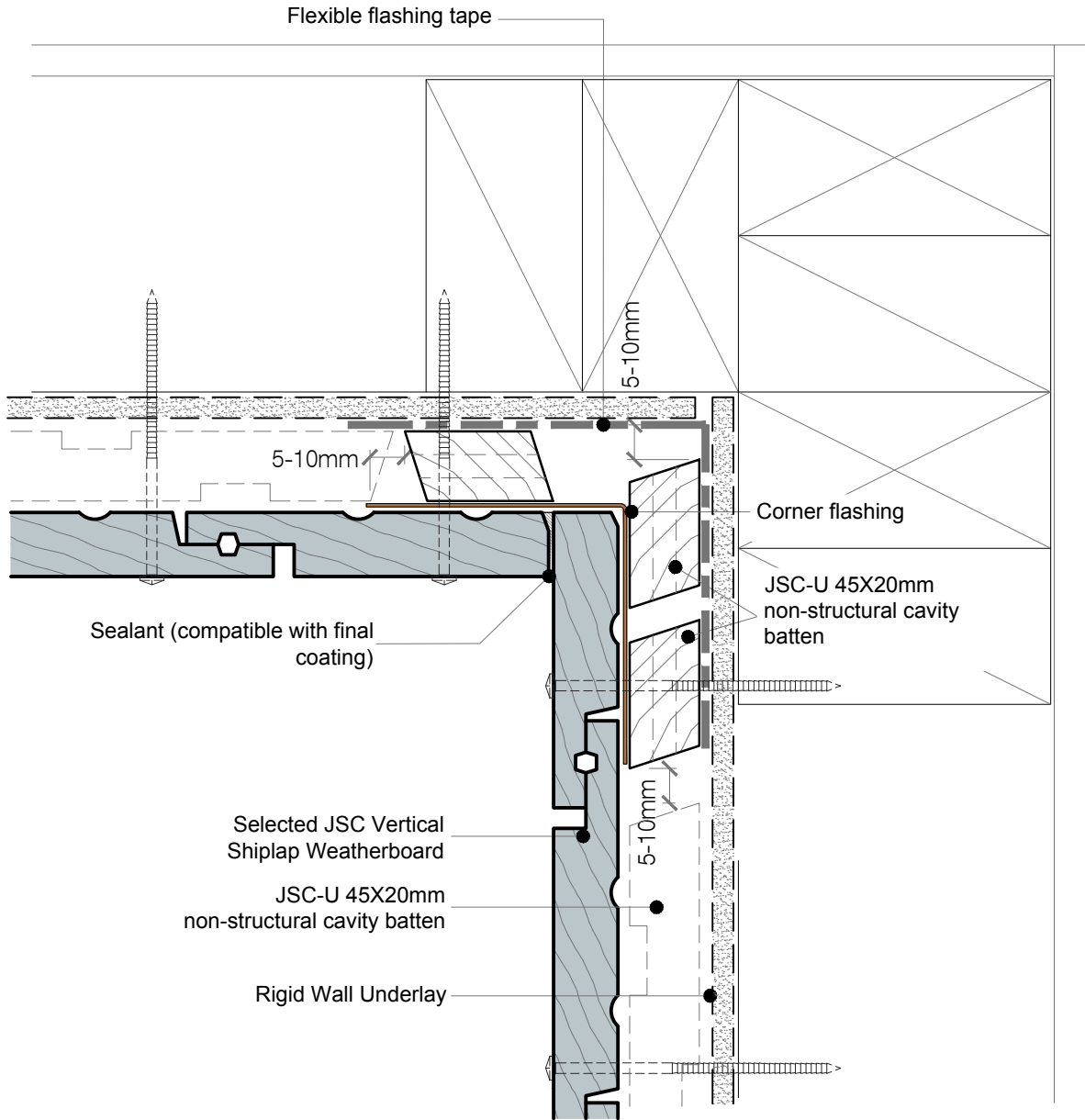

NOTES:

- Machine cavity battens down as required (5mm max) to accommodate corner flashing.
- Cut horizontal and vertical cavity battens on a 20-30° angle, sloping away from the framing.

• TO BE READ IN CONJUNCTION WITH COMPLETE JSC VERTICLAD SYSTEM LITERATURE

CodeMark
CMNZ30084

JSC PREMIUM ARCHITECTURAL & BUILDING SOLUTIONS

jsc.co.nz
TechHelp@jsc.co.nz | (09) 412 2812

TYPE
VERTICAL SHIPLAP WB - 20MM CAVITY FIX
NAME
Internal Corner

• DETAILS MAY BE SUBJECT TO CHANGE WITHOUT NOTICE



SCAN IT FOR MORE INFORMATION

DRAWING SCALE 1:2 @ A4	ISSUE DATE 11/02/2026
DRAWING NUMBER JSC 20CR VS62	VERSION 2.6

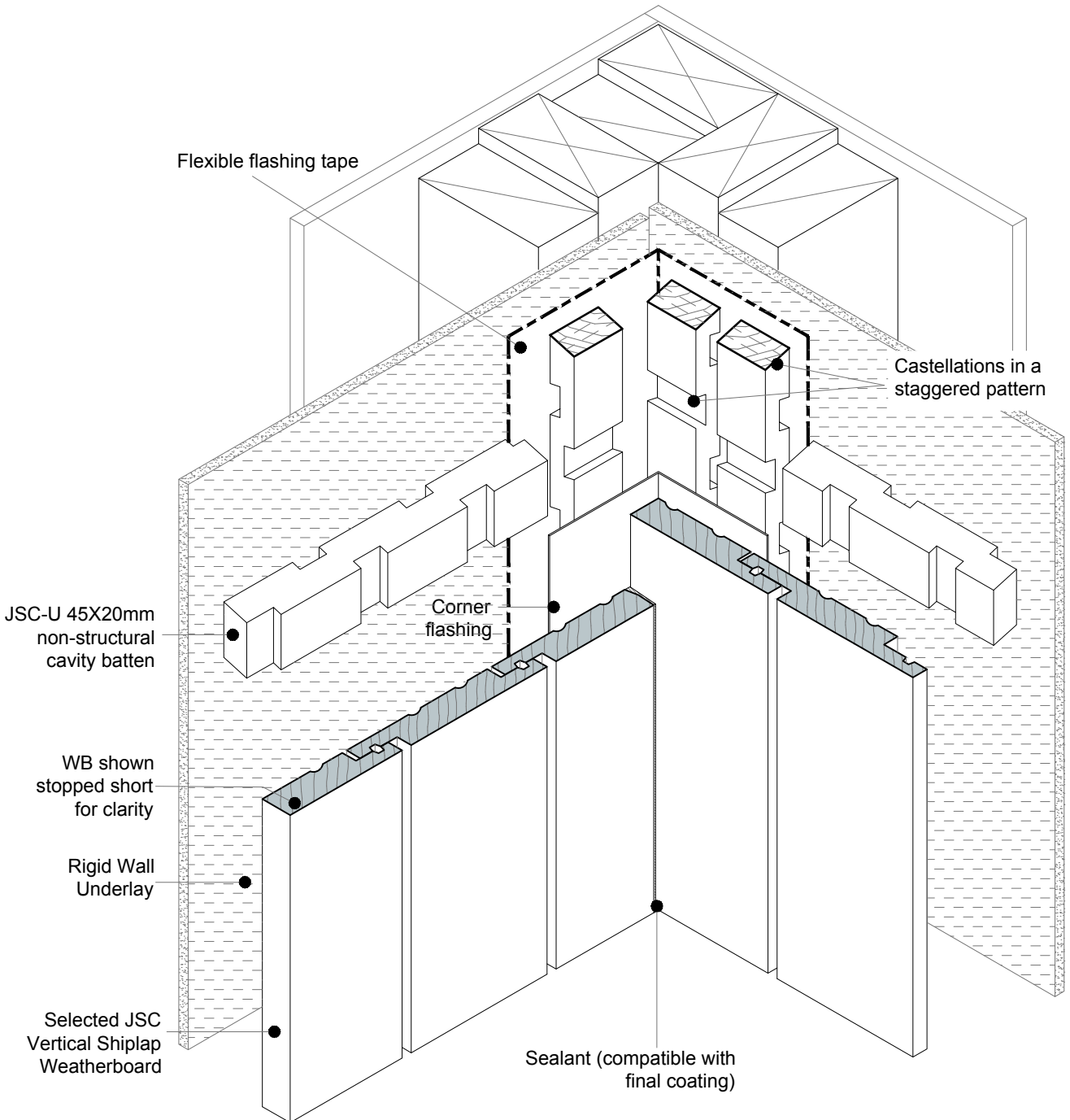

• TO BE READ IN CONJUNCTION WITH COMPLETE JSC VERTICLAD SYSTEM LITERATURE

CodeMark
CMNZ30084



jsc.co.nz
TechHelp@jsc.co.nz | (09) 412 2812

TYPE
VERTICAL SHIPLAP WB - 20MM CAVITY FIX

NAME
3D - Internal Corner

• DETAILS MAY BE SUBJECT TO CHANGE WITHOUT NOTICE



SCAN IT FOR MORE INFORMATION

DRAWING SCALE 1:2 @ A4	ISSUE DATE 11/02/2026
DRAWING NUMBER JSC 20CR VS63	VERSION 2.6

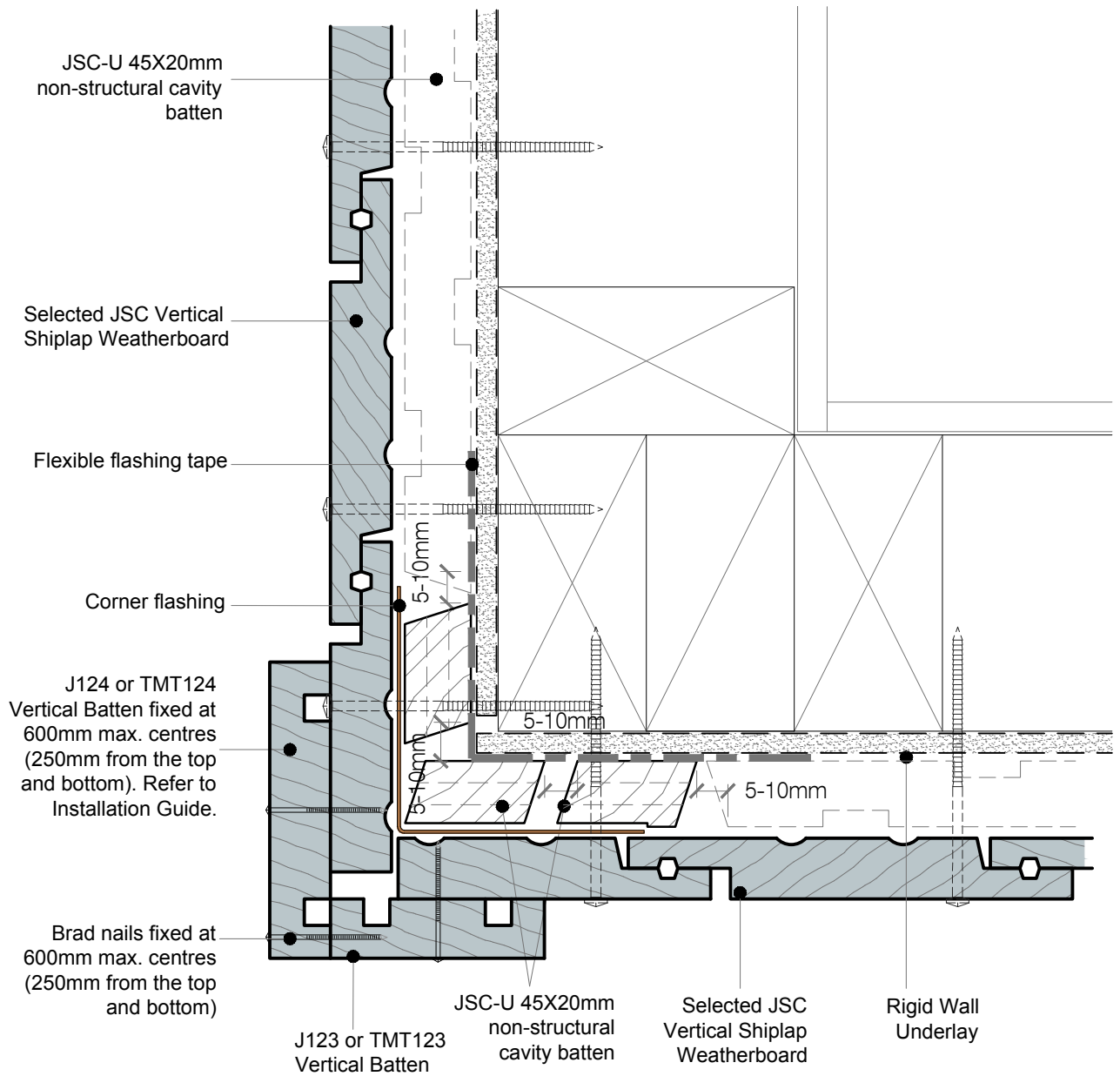

NOTES:

- Machine cavity battens down as required (5mm max) to accommodate corner flashing.
- Cut horizontal and vertical cavity battens on a 20-30° angle, sloping away from the framing.
- For Very High (VH) and Extra High (EH) wind zones, a solid batten (non-castellated) is required down one side of a significant external corner (change in elevation) to provide pressure isolation between elevations.
- JSC recommends this detail to be used for paint finished weatherboards.
- JSC recommends this detail to be used for pine weatherboards.

• TO BE READ IN CONJUNCTION WITH COMPLETE JSC VERTICLAD SYSTEM LITERATURE

CodeMark
CMNZ30084



jsc.co.nz
TechHelp@jsc.co.nz | (09) 412 2812

TYPE
VERTICAL SHIPLAP WB - 20MM CAVITY FIX
NAME
External Corner - Box Corner

• DETAILS MAY BE SUBJECT TO CHANGE WITHOUT NOTICE



SCAN IT FOR MORE INFORMATION

DRAWING SCALE 1:2 @ A4	ISSUE DATE 11/02/2026
DRAWING NUMBER JSC 20CR VS64	VERSION 2.6

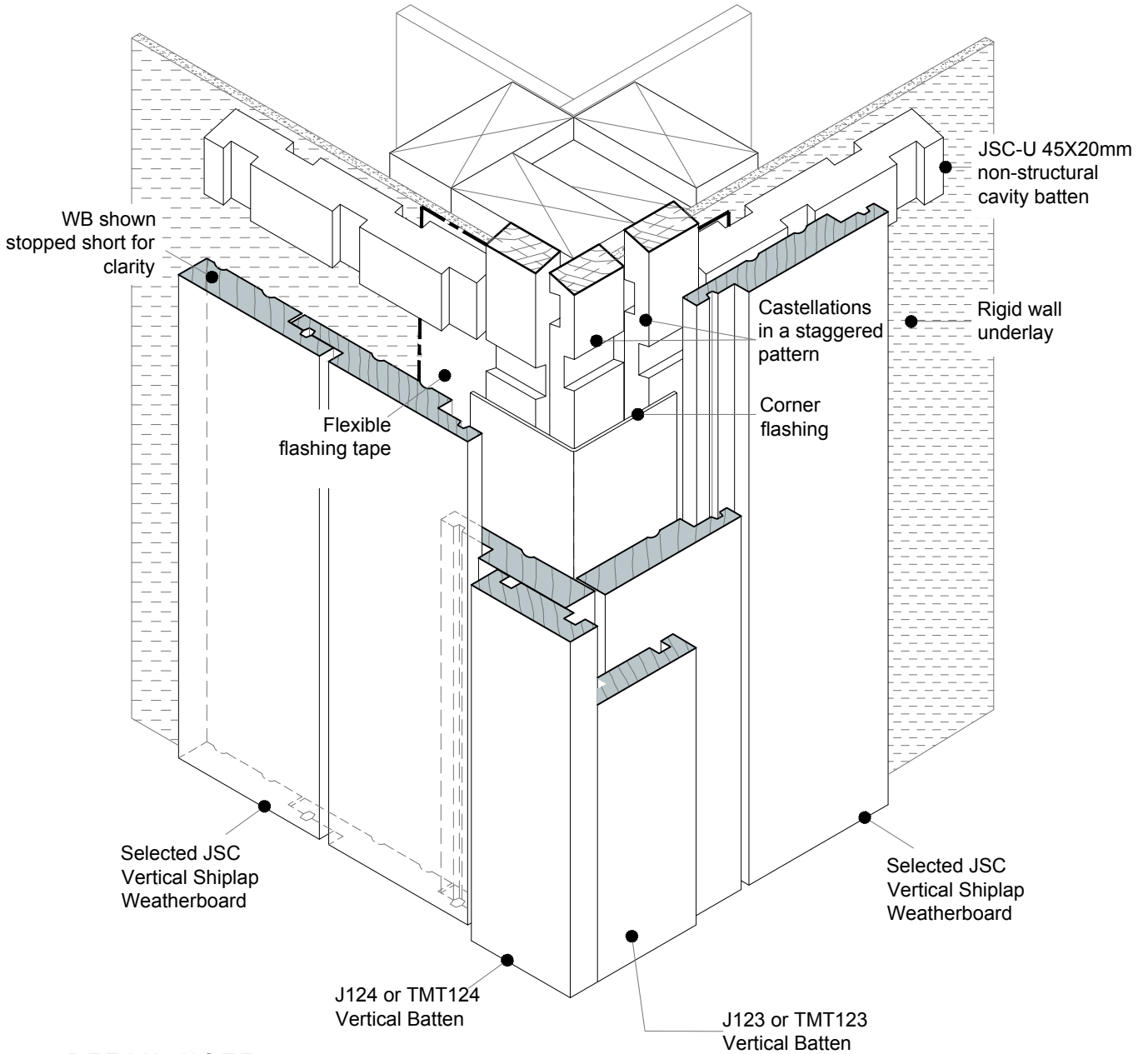

DETAIL NOTE :

- For Very High (VH) and Extra High (EH) wind zones (as defined NZS 3604), a solid batten (non castellated) is required down one side of a significant external corner (change in elevation) to provide pressure isolation between elevations.
- JSC recommends this detail to be used for paint finished weatherboards.
- JSC recommends this detail to be used for pine weatherboards.

• TO BE READ IN CONJUNCTION WITH COMPLETE JSC VERTICLAD SYSTEM LITERATURE

CodeMark
CMNZ30084



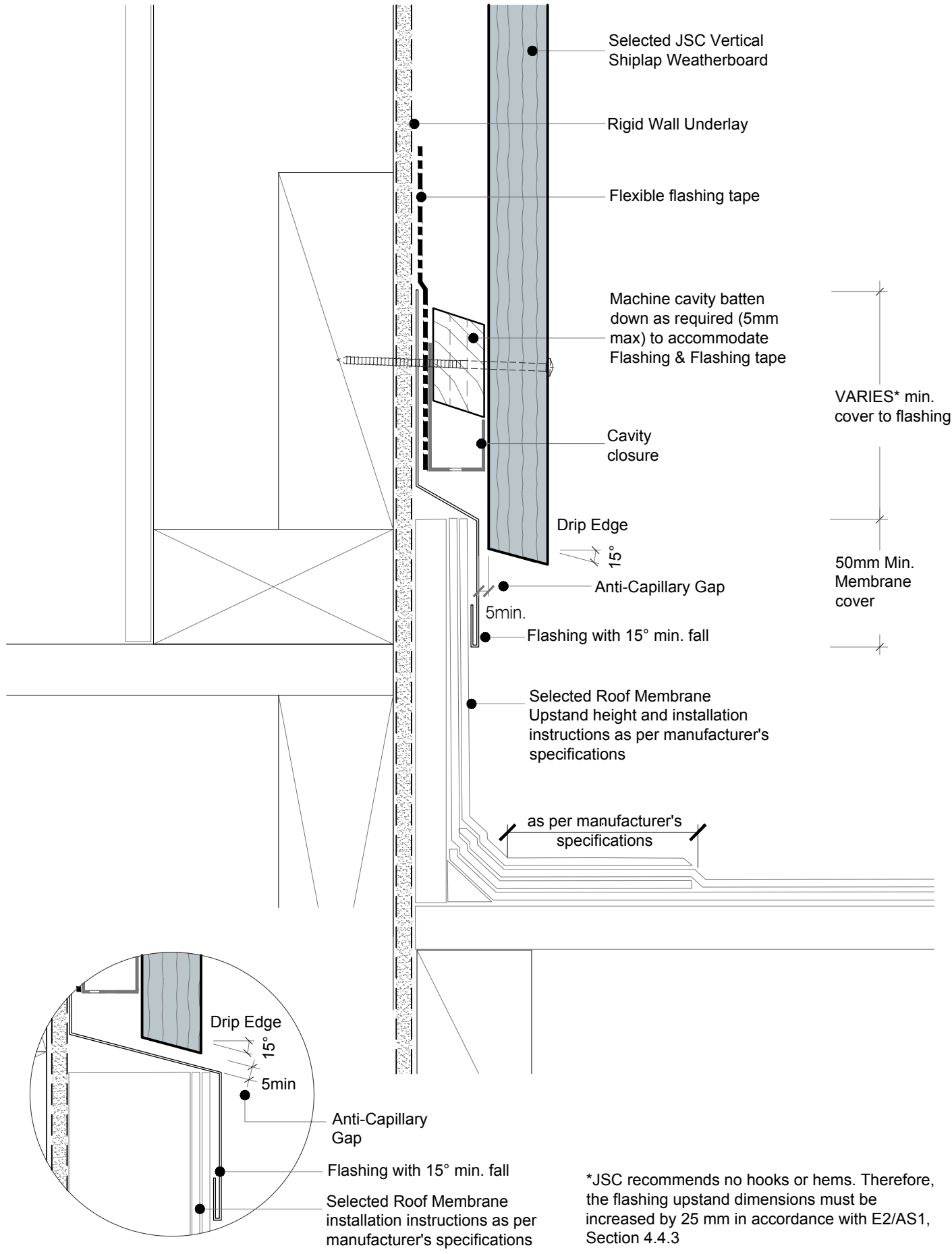

*JSC recommends no hooks or hems. Therefore, the flashing upstand dimensions must be increased by 25 mm in accordance with E2/AS1, Section 4.4.3

• TO BE READ IN CONJUNCTION WITH COMPLETE JSC VERTICLAD SYSTEM LITERATURE

CodeMark
CMNZ30084



DRAWING SCALE 1:2 @ A4	ISSUE DATE 11/02/2026
DRAWING NUMBER JSC 20CR VS70	VERSION 2.6

SEQUENCE :

1. Framing
2. Wall Underlay
3. Parapet Cavity battens
4. Packer to form slope
5. Flexible Flashing tape

DETAIL NOTE :

REFER TO E2/AS1 FIGURE 6.2.3.1B FOR SADDLE FLASHING DIMENSIONS

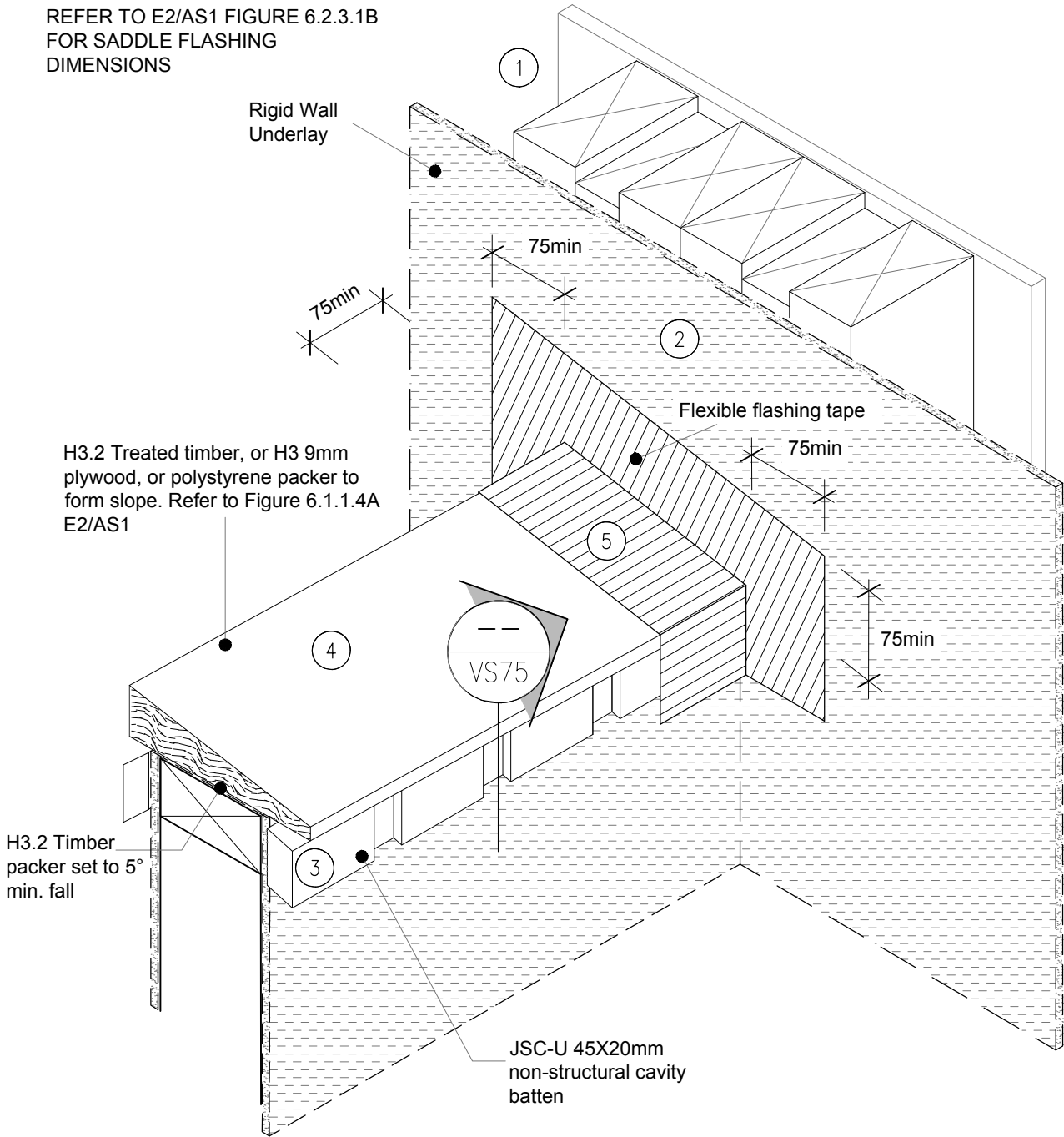

• TO BE READ IN CONJUNCTION WITH COMPLETE JSC VERTICLAD SYSTEM LITERATURE

CodeMark
CMNZ30084



jsc.co.nz
TechHelp@jsc.co.nz | (09) 412 2812

TYPE
VERTICAL SHIPLAP WB - 20MM CAVITY FIX
NAME
Parapet Saddle Flashing - Stage One

• DETAILS MAY BE SUBJECT TO CHANGE WITHOUT NOTICE



SCAN IT FOR MORE INFORMATION

DRAWING SCALE NTS	ISSUE DATE 11/02/2026
DRAWING NUMBER JSC 20CR VS71a	VERSION 2.6

SEQUENCE :

1. Framing
2. Wall Underlay
3. Parapet Cavity battens
4. Packer to form slope
5. Flexible Flashing tape
6. Cavity battens on wall
7. Corner flashings

DETAIL NOTE :

REFER TO E2/AS1 FIGURE 6.2.3.1B FOR SADDLE FLASHING DIMENSIONS

Care must be taken to not tear the Rigid Wall Underlay with cavity batten sharp bevelled edge. Cavity batten might be planed to remove sharp edge

H3.2 Treated timber, or H3 9mm plywood, or polystyrene packer to form slope. Refer to 6.1.1.4A E2/AS1

H3.2 Timber packer set to 5° min. fall

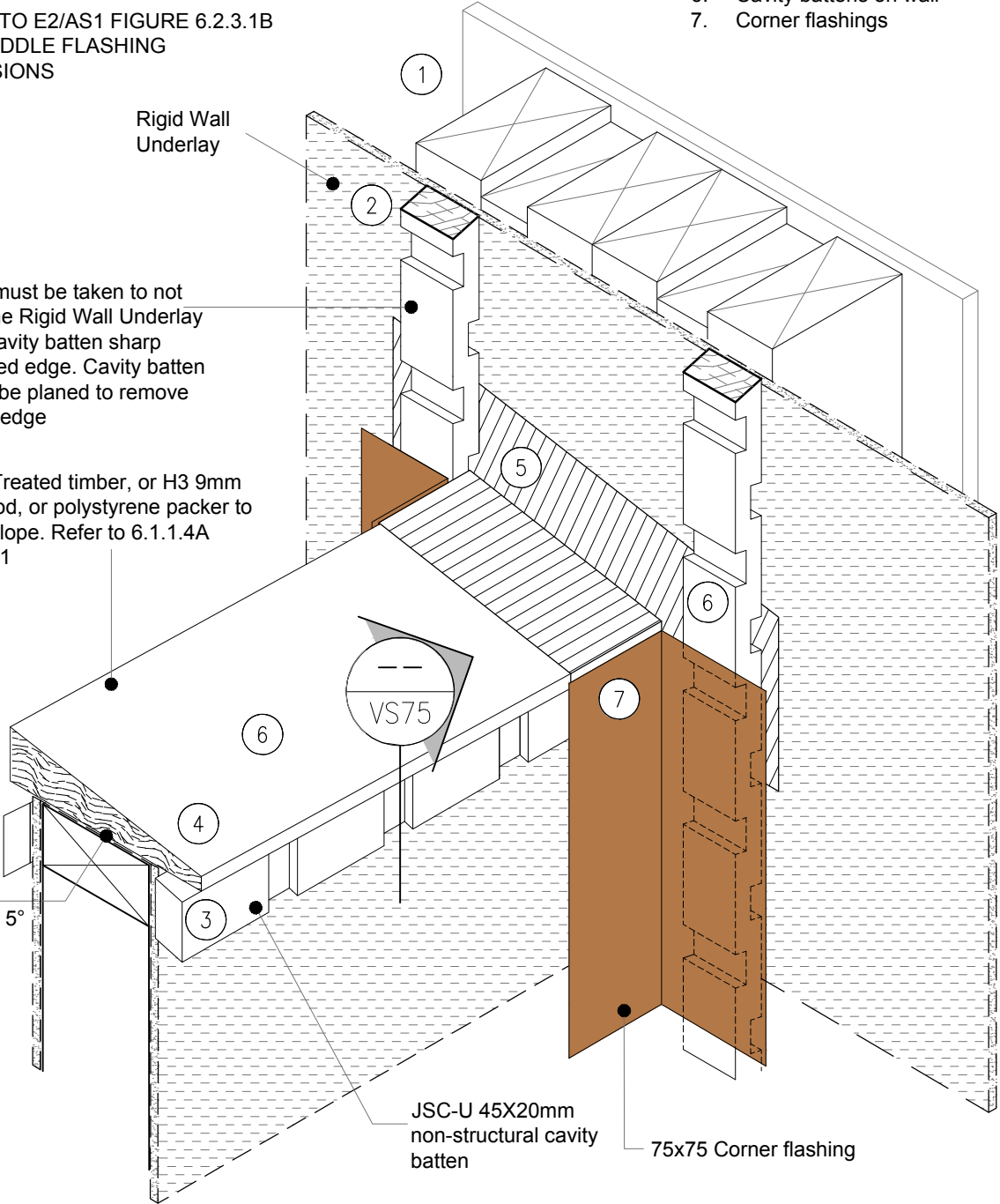

JSC-U 45X20mm non-structural cavity batten

75x75 Corner flashing

• TO BE READ IN CONJUNCTION WITH COMPLETE JSC VERTICLAD SYSTEM LITERATURE

CodeMark
CMNZ30084



DRAWING SCALE NTS	ISSUE DATE 11/02/2026
DRAWING NUMBER JSC 20CR VS71b	VERSION 2.6

DETAIL NOTE :

REFER TO E2/AS1 FIGURE 6.2.3.1B FOR SADDLE FLASHING DIMENSIONS

SEQUENCE :

- 8. Cladding
- 9. Separation layer
- 10. Saddle Flashing

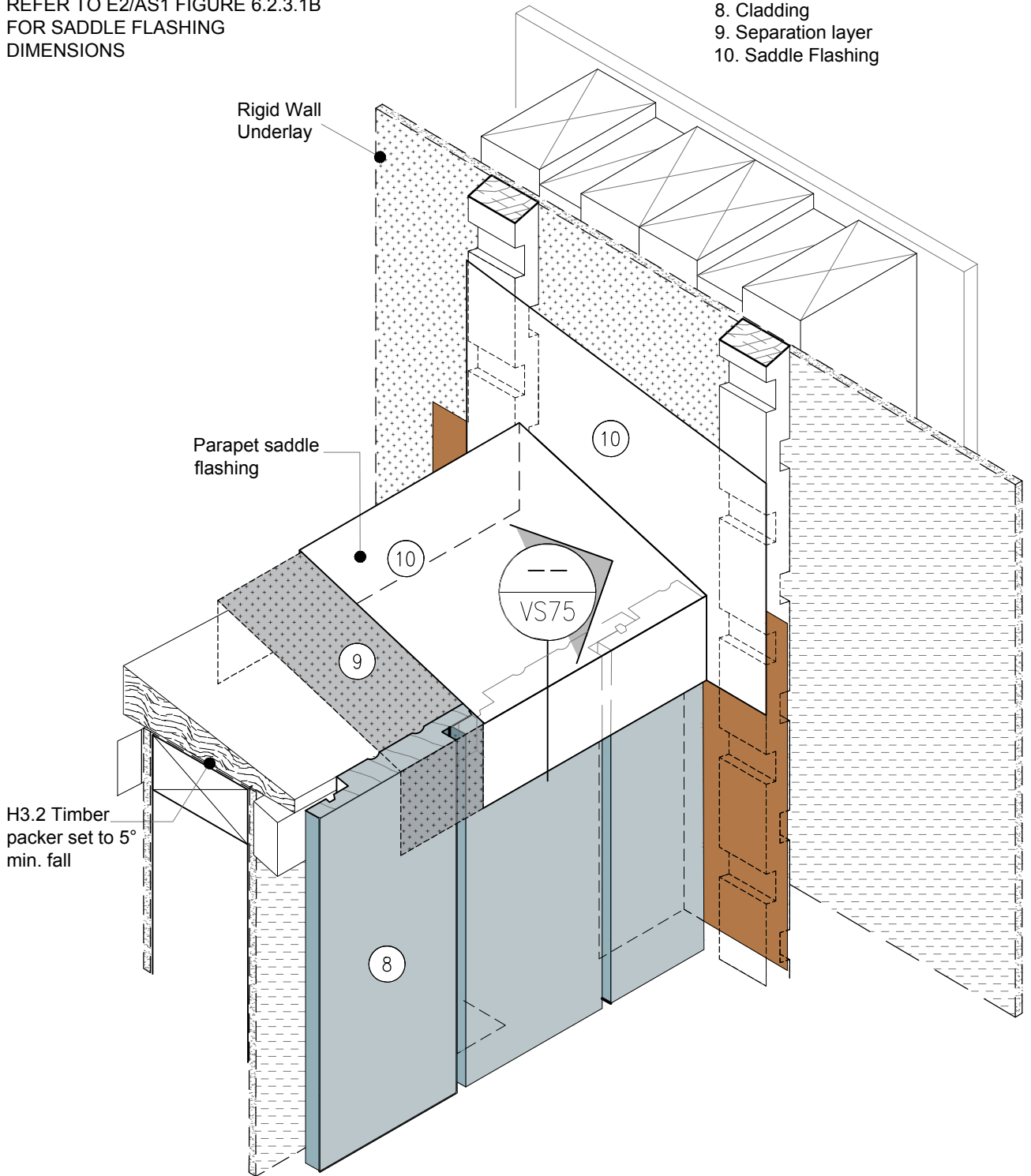

• TO BE READ IN CONJUNCTION WITH COMPLETE JSC VERTICLAD SYSTEM LITERATURE

CodeMark
CMNZ30084



jsc.co.nz
TechHelp@jsc.co.nz | (09) 412 2812

TYPE
VERTICAL SHIPLAP WB - 20MM CAVITY FIX

NAME
Parapet Saddle Flashing - Stage Three

• DETAILS MAY BE SUBJECT TO CHANGE WITHOUT NOTICE



SCAN IT FOR MORE INFORMATION

DRAWING SCALE NTS	ISSUE DATE 11/02/2026
DRAWING NUMBER JSC 20CR VS71c	VERSION 2.6

DETAIL NOTE :

REFER TO E2/AS1 FIGURE 6.2.3.1B
FOR SADDLE FLASHING
DIMENSIONS

SEQUENCE :

- 11. Cladding over saddle flashing
- 12. Cap flashing

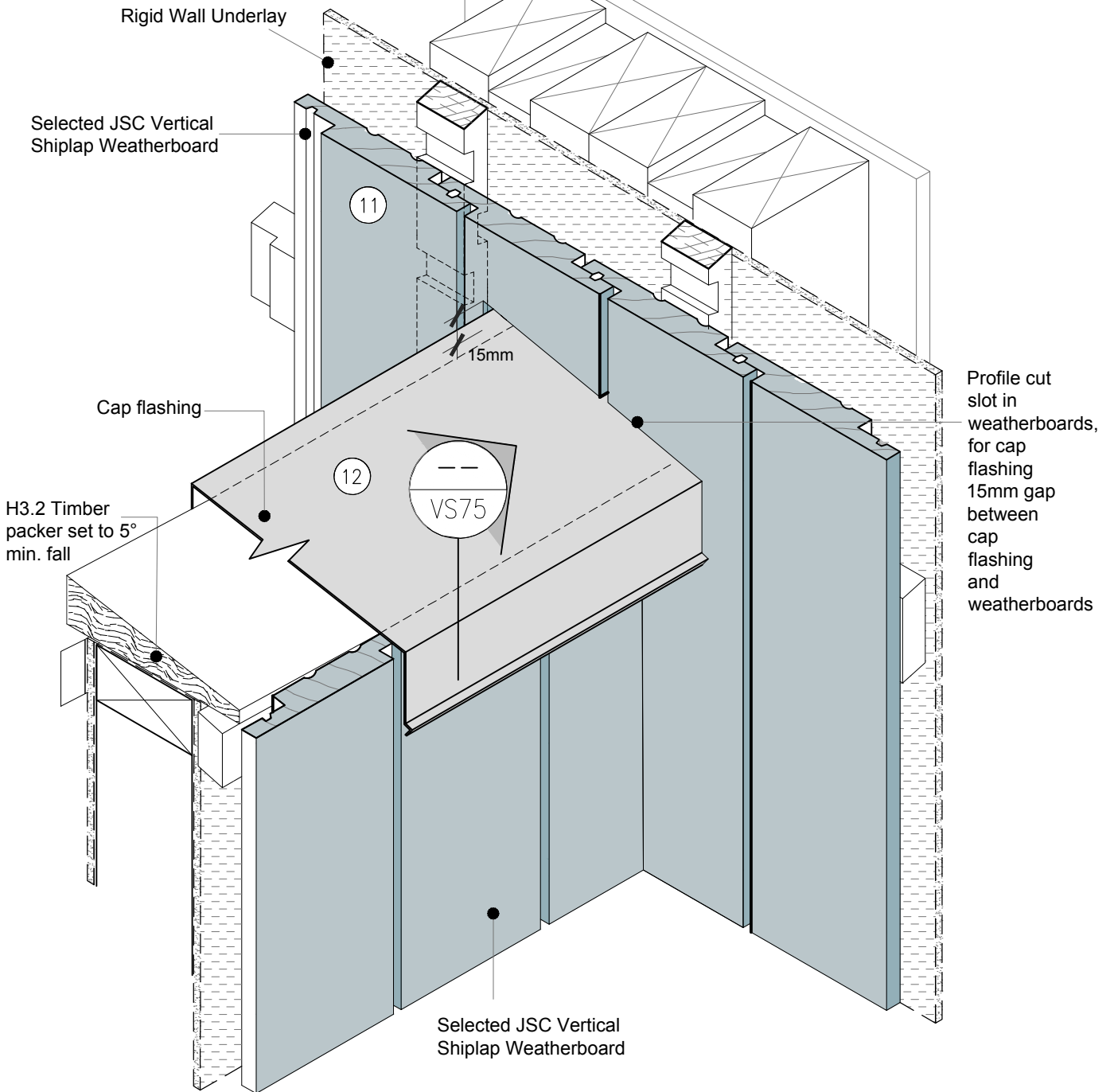

• TO BE READ IN CONJUNCTION WITH COMPLETE JSC VERTICLAD SYSTEM LITERATURE

CodeMark
CMNZ30084



jsc.co.nz
TechHelp@jsc.co.nz | (09) 412 2812

TYPE
VERTICAL SHIPLAP WB - 20MM CAVITY FIX
NAME
Parapet Saddle Flashing - Stage Four

• DETAILS MAY BE SUBJECT TO CHANGE WITHOUT NOTICE



SCAN IT FOR MORE INFORMATION

DRAWING SCALE 1:2 @ A4	ISSUE DATE 29/02/2026
DRAWING NUMBER JSC 20CR VS71d	VERSION 2.6

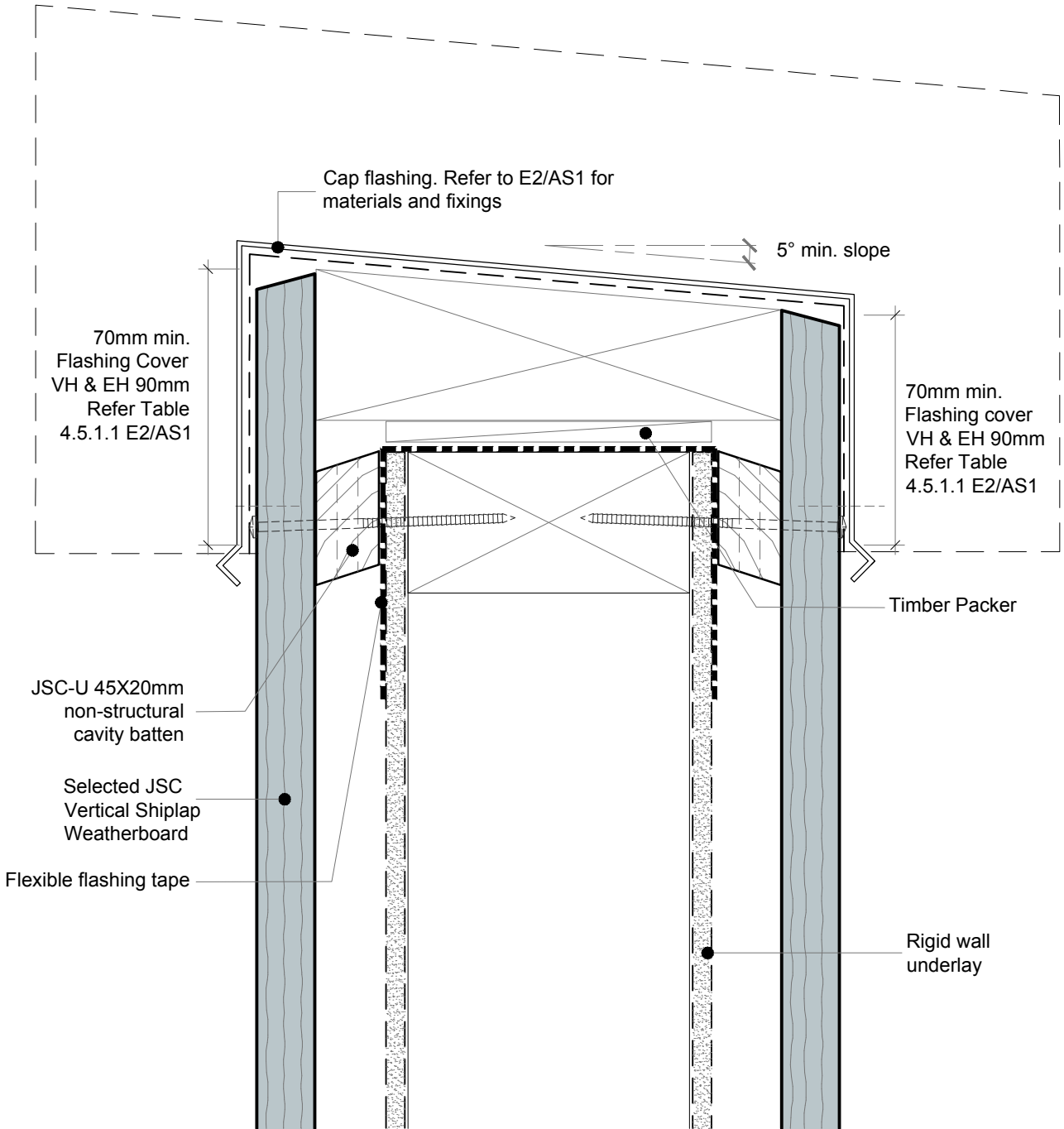

• TO BE READ IN CONJUNCTION WITH COMPLETE JSC VERTICLAD SYSTEM LITERATURE

CodeMark
CMNZ30084



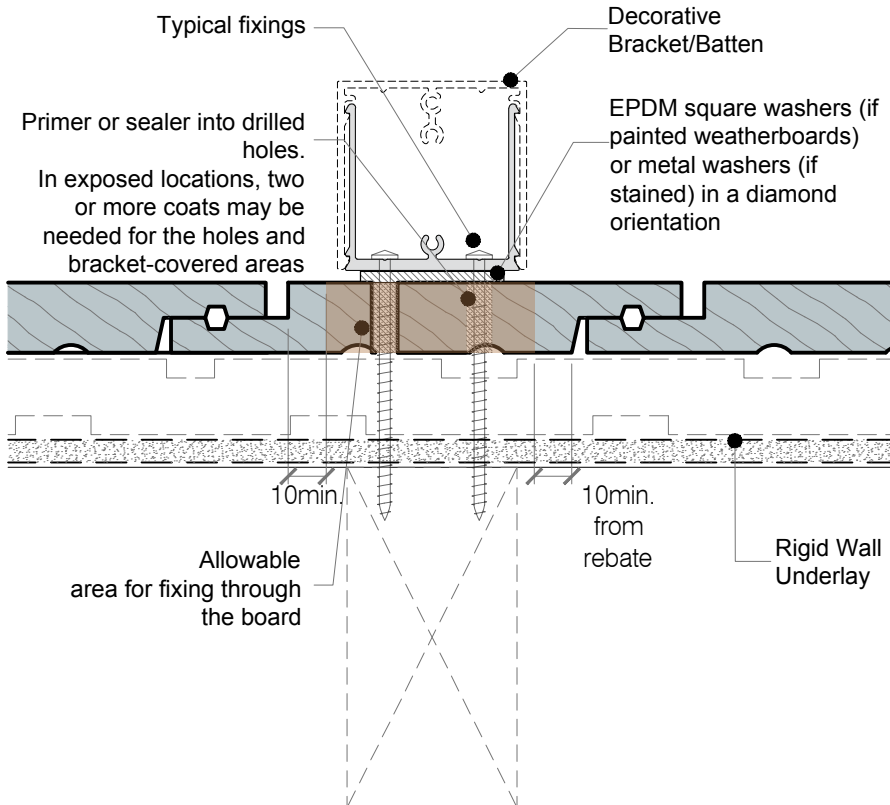
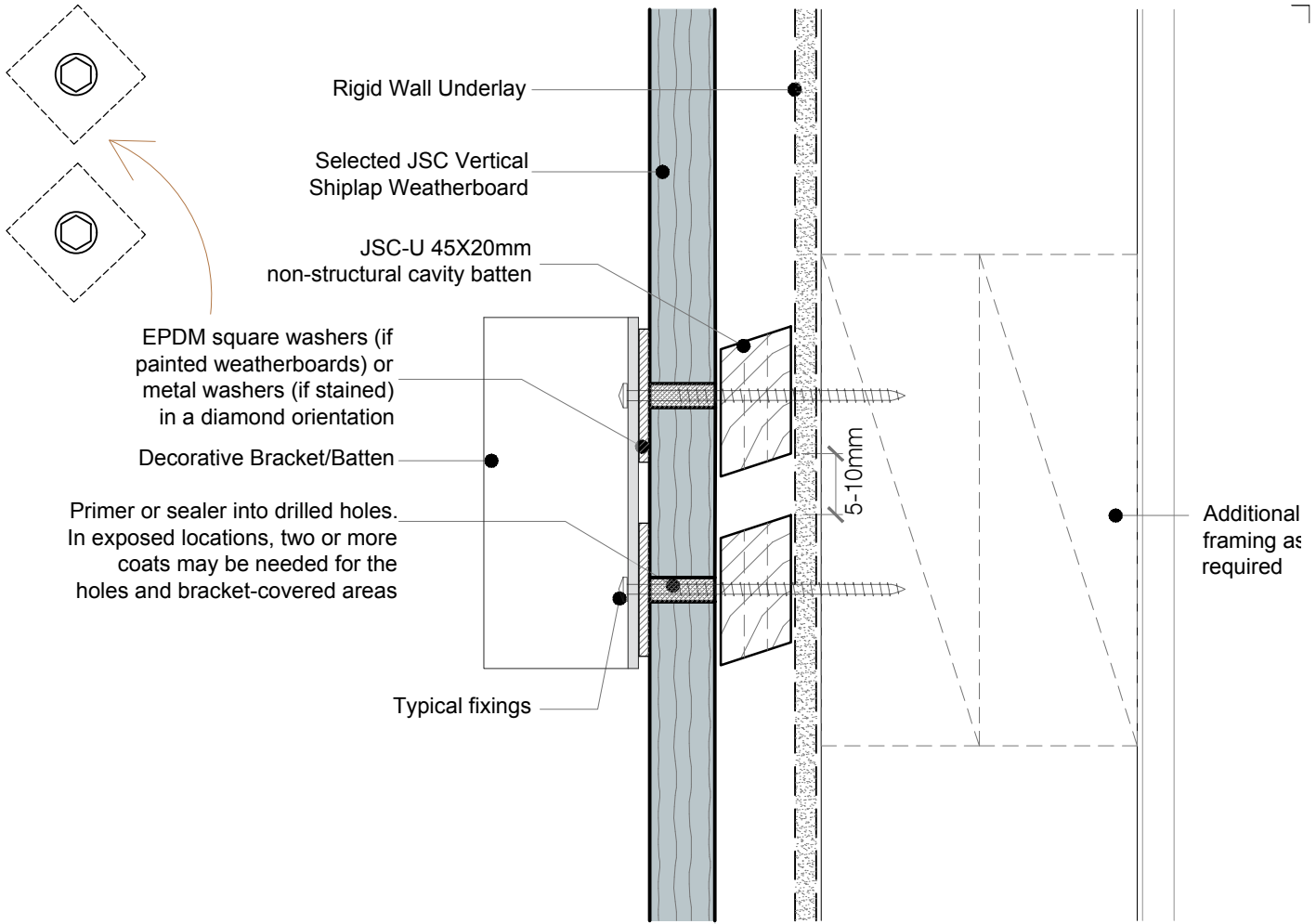

NOTES:

- This detail is to show penetration through the cladding. Framing structure and fixings as per NZS3604:2011 or Specific engineered design.
- Refer to this detail as a principle rather than specific instruction.
- Durable and compatible materials, in accordance with the material selection and compatibility tables in Appendix C of E2/AS1 Fourth Edition.
- If bracket fixings interfere with weatherboard laps, consider an alternative, such as an offset bracket.
- Fixings should be sufficient for the load, with this detail intended for low to medium forces (decorative batten)

Any penetration or contact with the cladding should:

- Be coated for water resistance (e.g., two coats of stain).
- Be inspectable; avoid hidden high-risk penetrations.
- Be maintainable; brackets should be removable for inspection or treatment of weatherboards.

• TO BE READ IN CONJUNCTION WITH COMPLETE JSC VERTICLAD SYSTEM LITERATURE

CodeMark
CMNZ30084



DRAWING SCALE 1:2 @ A4	ISSUE DATE 11/02/2026
DRAWING NUMBER JSC 20CR VS77	VERSION 2.6

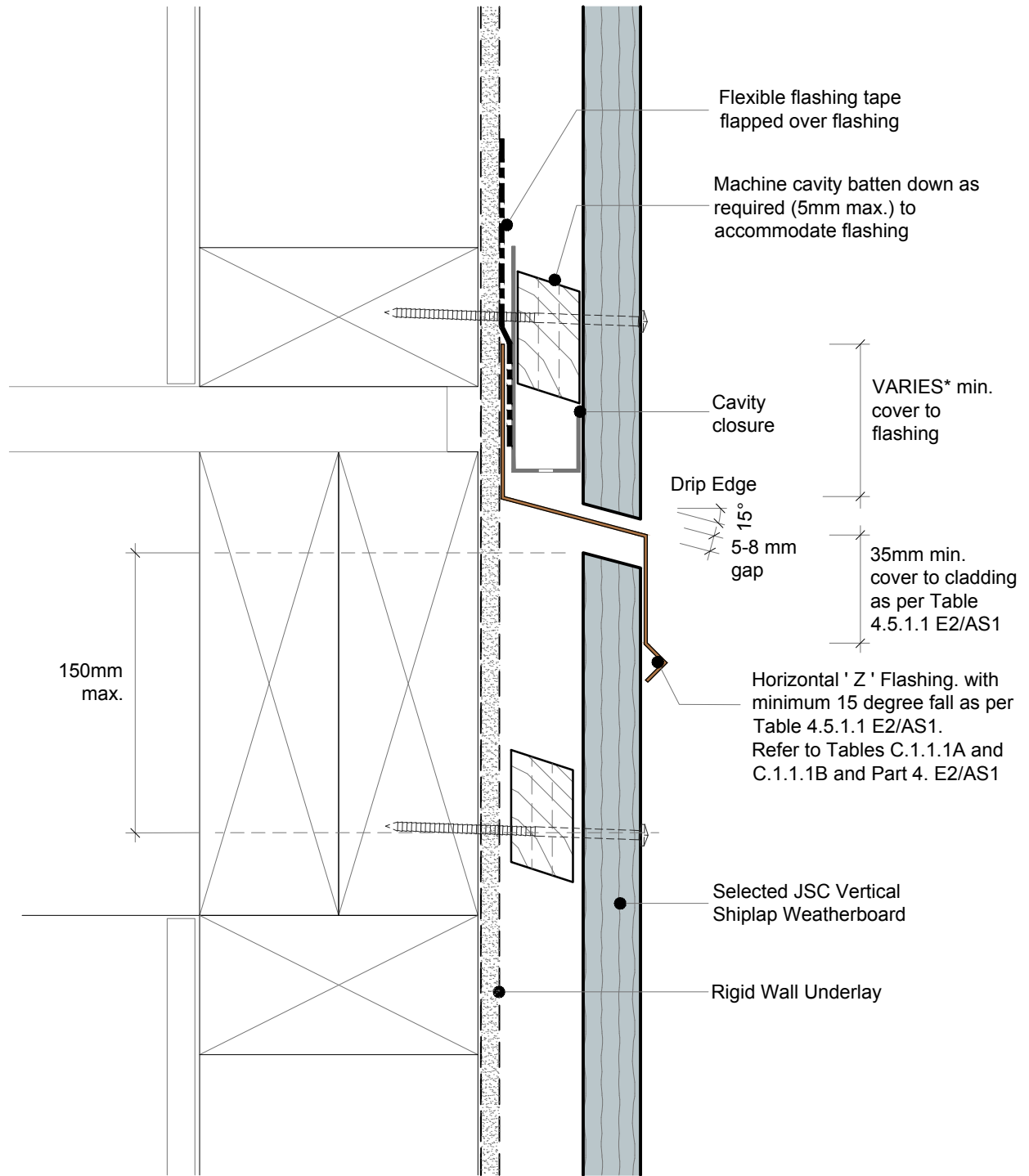

*JSC recommends no hooks or hems. Therefore, the flashing upstand dimensions must be increased by 25 mm in accordance with E2/AS1, Section 4.4.3

• TO BE READ IN CONJUNCTION WITH COMPLETE JSC VERTICLAD SYSTEM LITERATURE

CodeMark
CMNZ30084



jsc.co.nz
TechHelp@jsc.co.nz | (09) 412 2812

TYPE
VERTICAL SHIPLAP WB - 20MM CAVITY FIX
NAME
Inter Storey Joint

• DETAILS MAY BE SUBJECT TO CHANGE WITHOUT NOTICE



SCAN IT FOR MORE INFORMATION

DRAWING SCALE 1:2 @ A4	ISSUE DATE 11/02/2026
DRAWING NUMBER JSC 20CR VS80	VERSION 2.6

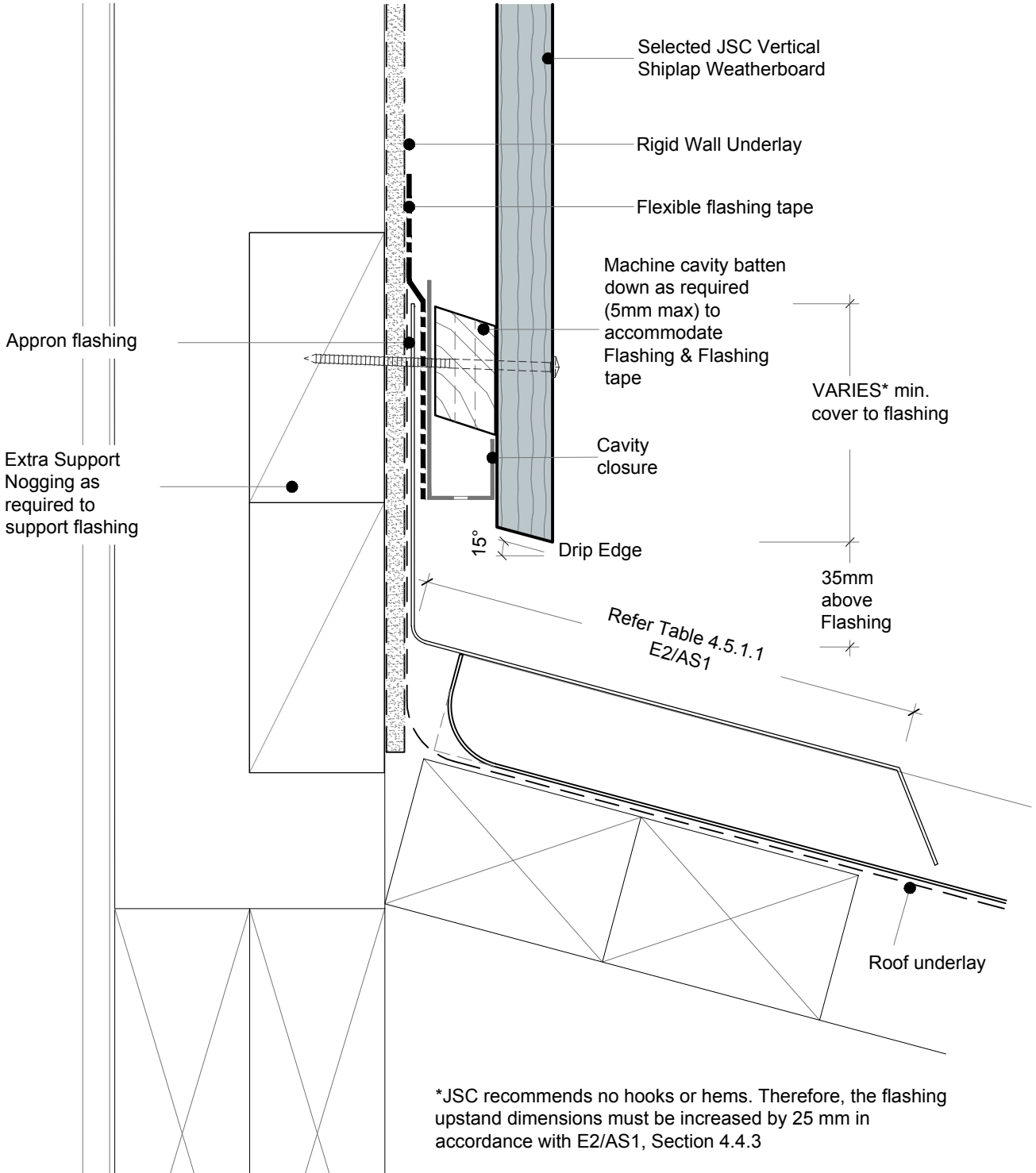

• TO BE READ IN CONJUNCTION WITH COMPLETE JSC VERTICLAD SYSTEM LITERATURE

CodeMark
CMNZ30084



DRAWING SCALE 1:2 @ A4	ISSUE DATE 11/02/2026
DRAWING NUMBER JSC 20CR VS81	VERSION 2.6

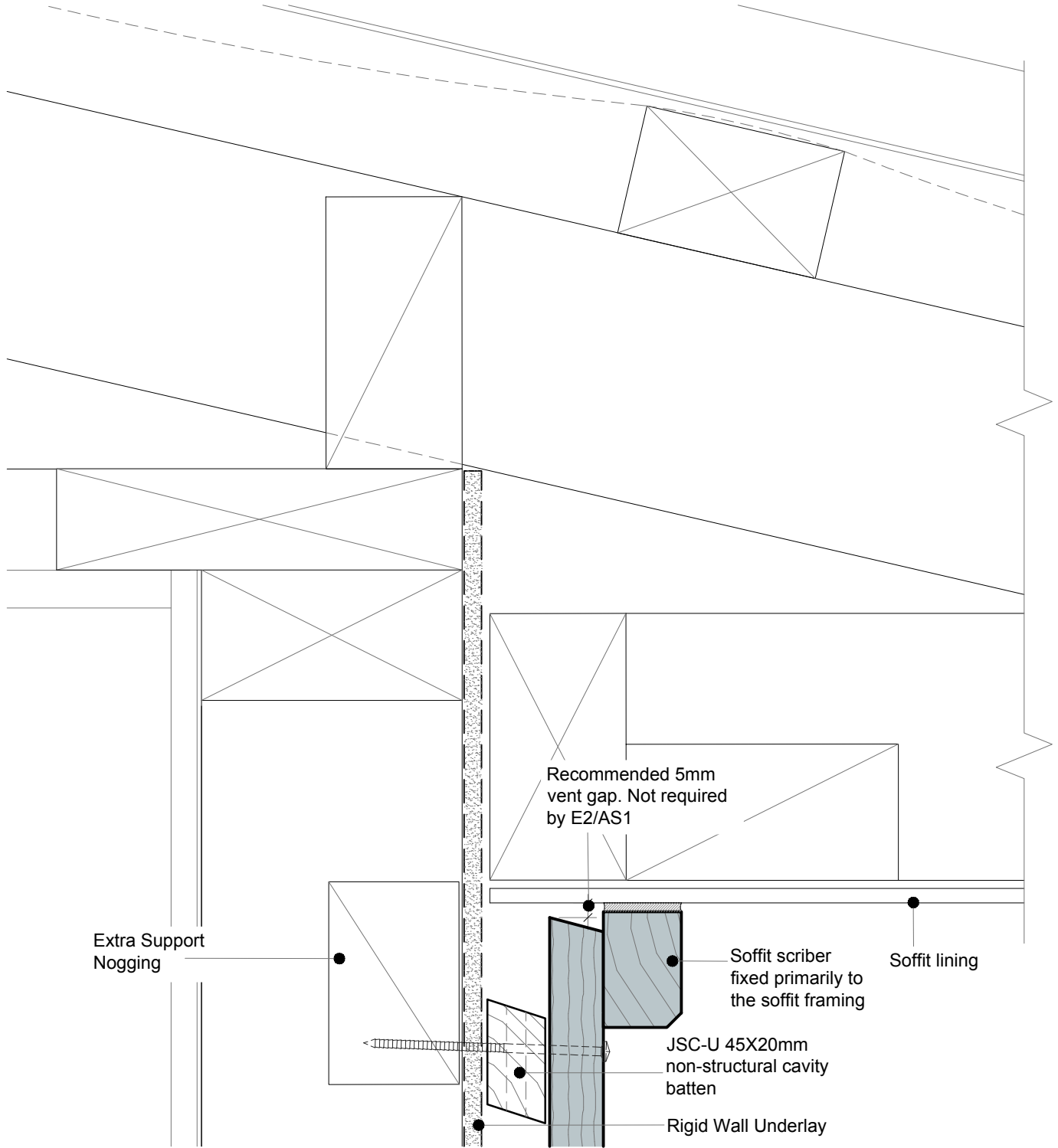

• TO BE READ IN CONJUNCTION WITH COMPLETE JSC VERTICLAD SYSTEM LITERATURE

CodeMark
CMNZ30084



jsc.co.nz
TechHelp@jsc.co.nz | (09) 412 2812

TYPE
VERTICAL SHIPLAP WB - 20MM CAVITY FIX

NAME
Soffit Detail at Wall

• DETAILS MAY BE SUBJECT TO CHANGE WITHOUT NOTICE



SCAN IT FOR MORE INFORMATION

DRAWING SCALE 1:2 @ A4	ISSUE DATE 11/02/2026
DRAWING NUMBER JSC 20CR VS82	VERSION 2.6

Flashing Required When
 1. Roof Pitch 10° or less
 2. Soffit 100mm or less
 3. Wind Zone VH or EH

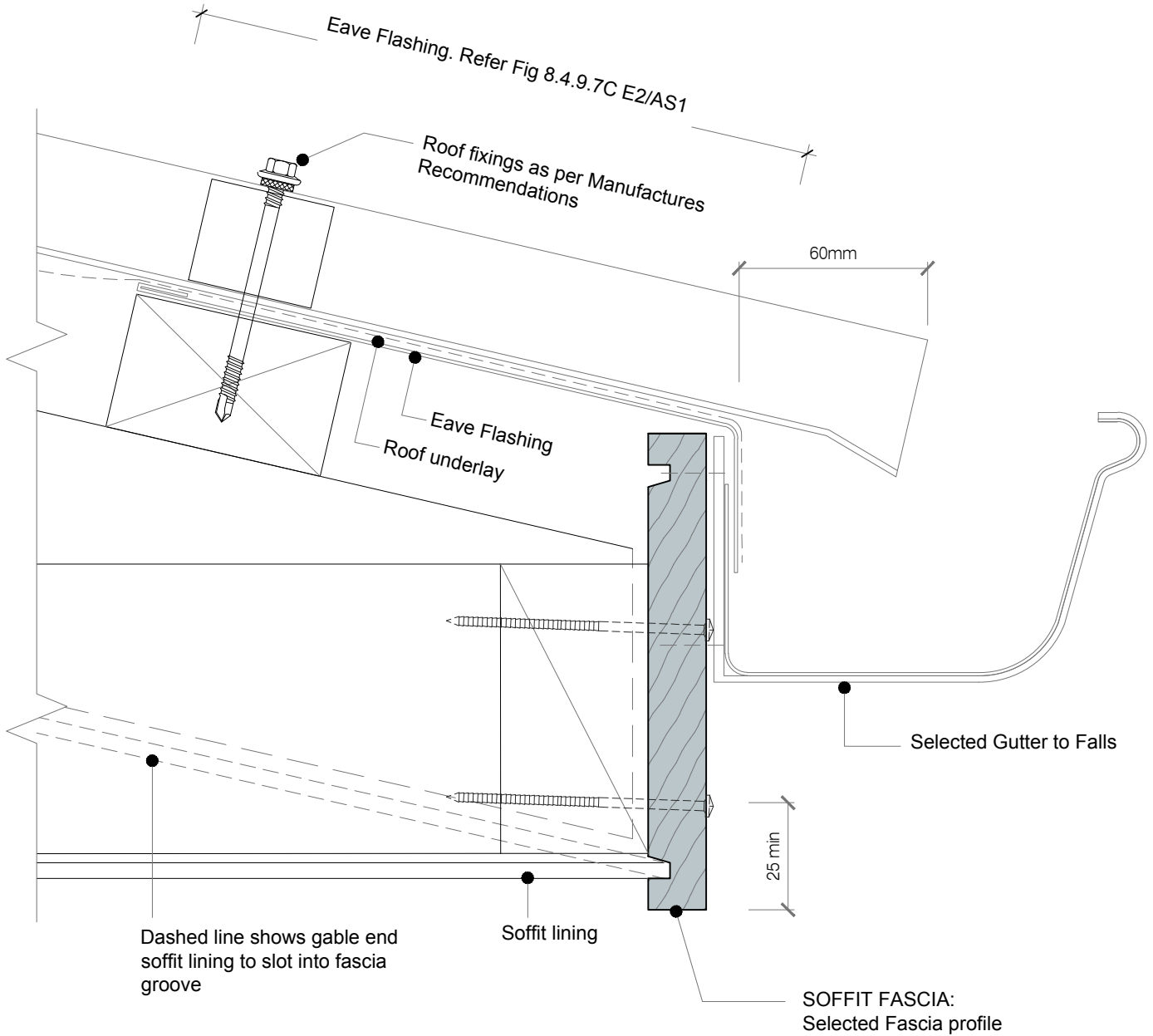

• TO BE READ IN CONJUNCTION WITH COMPLETE JSC VERTICLAD SYSTEM LITERATURE

CodeMark
 CMNZ30084



DRAWING SCALE 1:2 @ A4	ISSUE DATE 11/02/2026
DRAWING NUMBER JSC 20CR VS83	VERSION 2.6

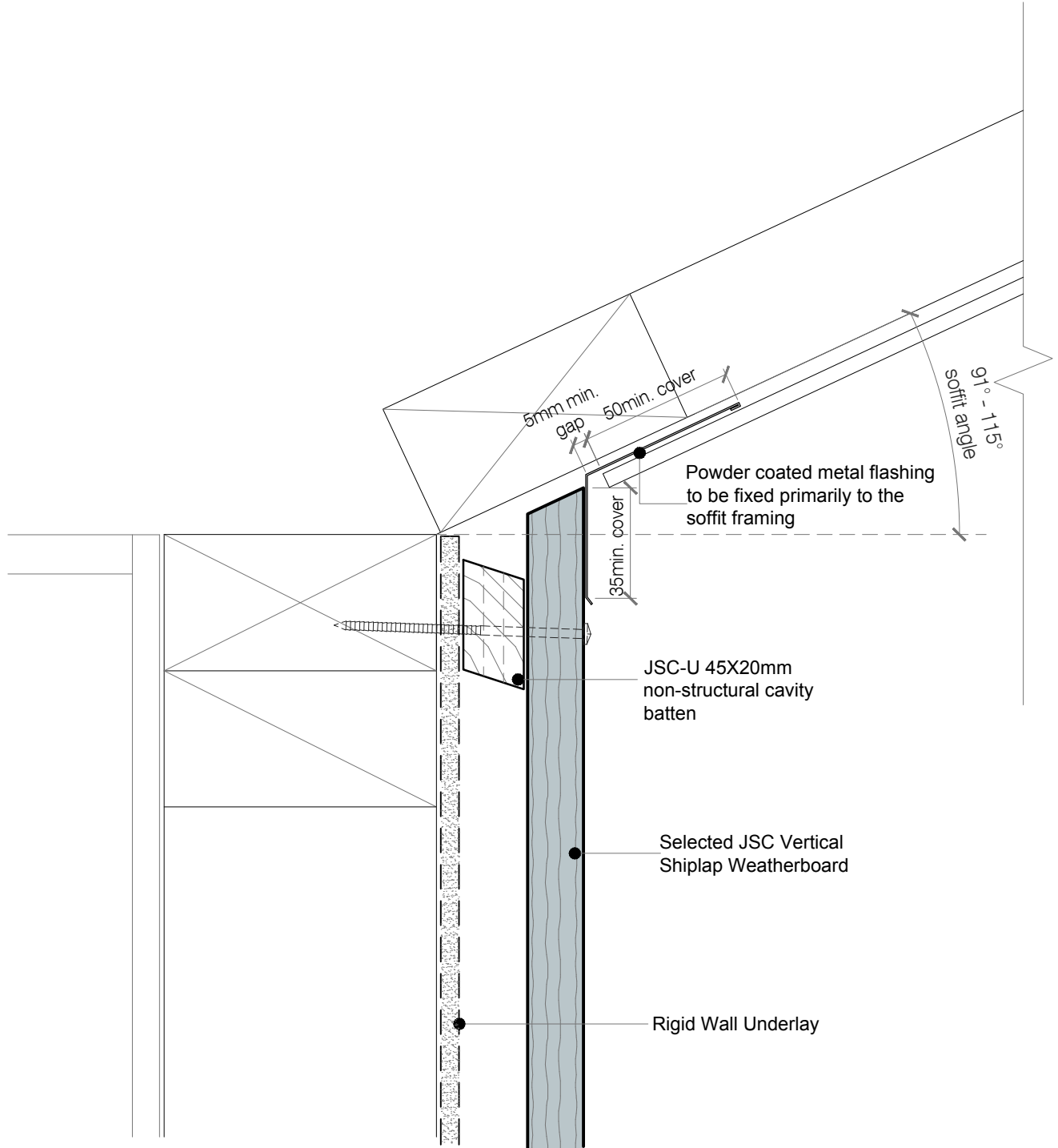

• TO BE READ IN CONJUNCTION WITH COMPLETE JSC VERTICLAD SYSTEM LITERATURE

CodeMark
CMNZ30084



jsc.co.nz
TechHelp@jsc.co.nz | (09) 412 2812

TYPE
VERTICAL SHIPLAP WB - 20MM CAVITY FIX

NAME
Raking Soffit at Wall

• DETAILS MAY BE SUBJECT TO CHANGE WITHOUT NOTICE



SCAN IT FOR MORE INFORMATION

DRAWING SCALE 1:2 @ A4	ISSUE DATE 11/02/2026
DRAWING NUMBER JSC 20CR VS84	VERSION 2.6

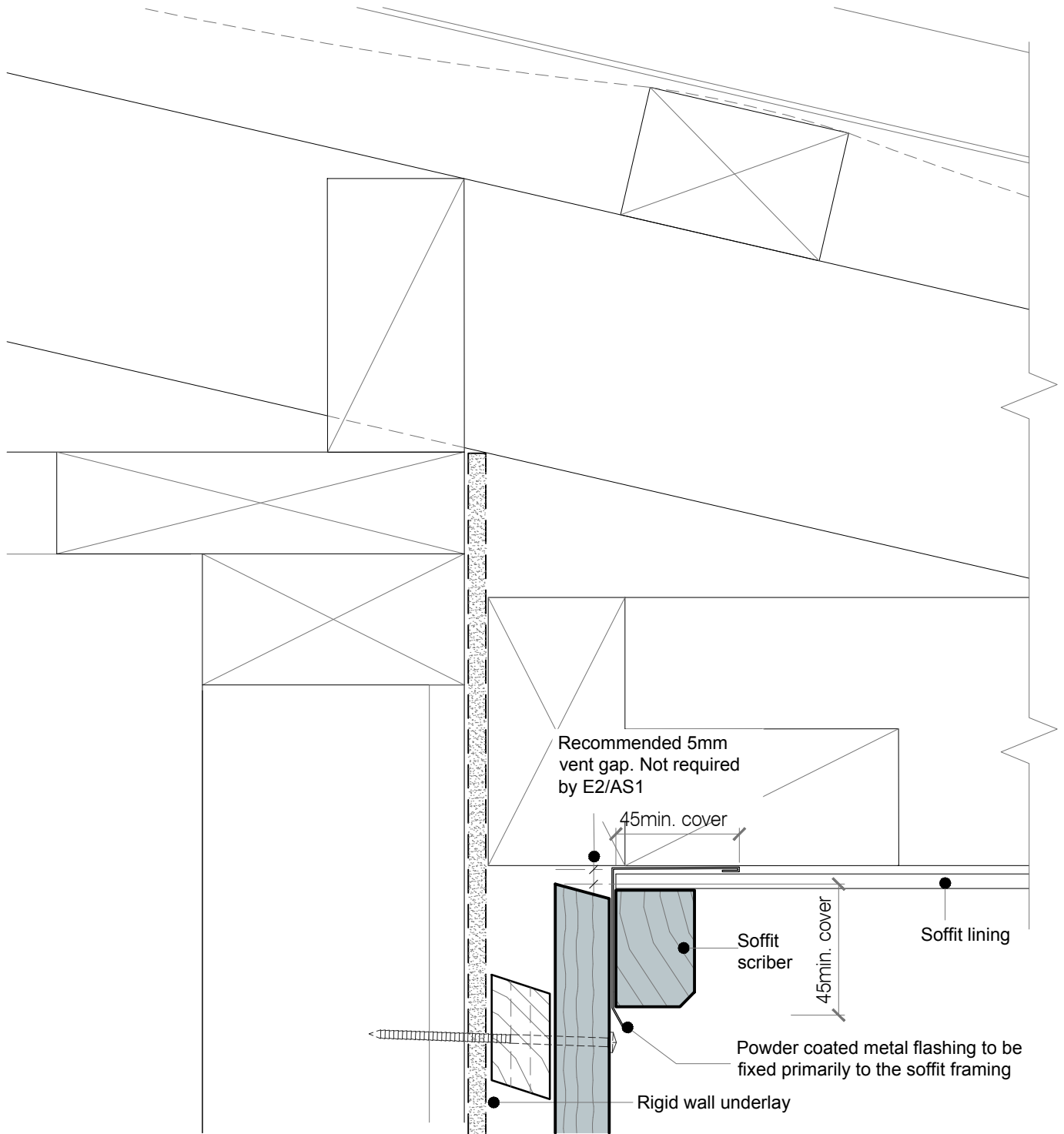

DETAIL NOTES :

1. 45° max. fall along soffit junction
2. Refer to BRANZ Build 158-27 - Build Right Soffit Details at Gable Verge

• TO BE READ IN CONJUNCTION WITH COMPLETE JSC VERTICLAD SYSTEM LITERATURE

CodeMark
CMNZ30084



DRAWING SCALE 1:2 @ A4	ISSUE DATE 11/02/2026
DRAWING NUMBER JSC 20CR VS85	VERSION 2.6

Weatherboards:

- Single fix at each cavity batten with annular grooved nails (stainless steel 316 or silicon bronze) as per NZBC E2/AS1 Table C.3.1.1
- Pre-drill holes approximately 1mm smaller than the nail gauge. Example: For a 75mm nail, use a 2.5mm drill
- Nail with slight (0-2°) upward slope
- Fixings to achieve a minimum of 30mm penetration into the framing
- Minimum 50mm from the ends of boards
- Use an accurate packer in the negative detail. Do not rely on clinch nails for spacing

Cavity battens:

- will be fixed by the cladding fixings, which will penetrate the wall framing. Battens only need temporary fixing until the cladding is fixed (E2/AS1 - Table C.3.1.1)
- must always be installed sloping away from the framing
- must have a 5-10mm gap between them

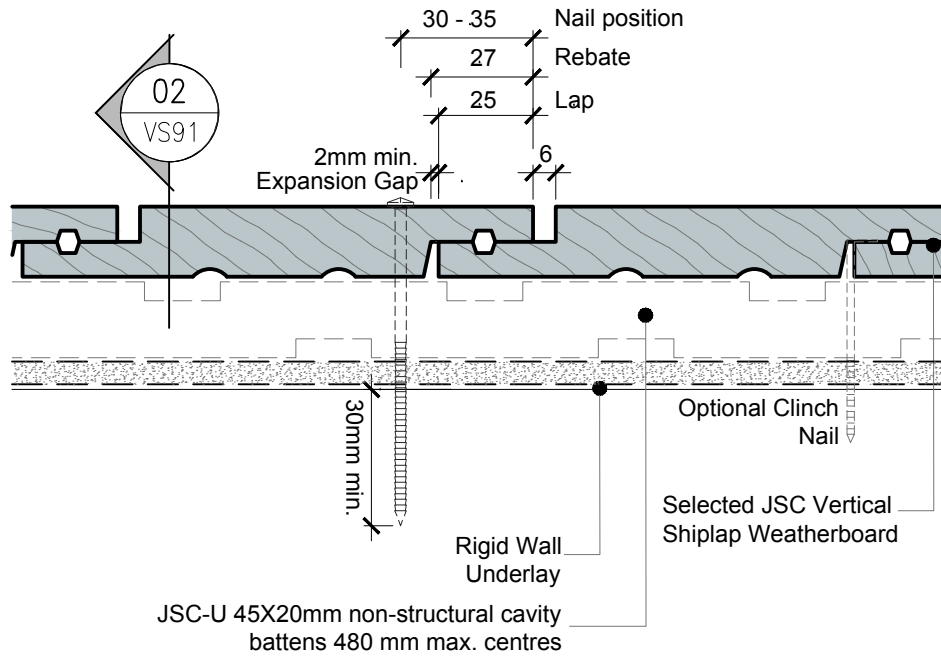

Plan Section 01

• TO BE READ IN CONJUNCTION WITH COMPLETE JSC VERTICLAD SYSTEM LITERATURE

CodeMark
CMNZ30084



jsc.co.nz
TechHelp@jsc.co.nz | (09) 412 2812

TYPE
 VERTICAL SHIPLAP WB - 20MM CAVITY FIX
NAME
 Weatherboard Fixing -Plan View
 • DETAILS MAY BE SUBJECT TO CHANGE WITHOUT NOTICE



SCAN IT FOR MORE INFORMATION

DRAWING SCALE 1:2 @ A4	ISSUE DATE 11/02/2026
DRAWING NUMBER JSC 20CR VS90	VERSION 2.6

Weatherboards:

- Single fix at each cavity batten with annular grooved nails (stainless steel 316 or silicon bronze) as per NZBC E2/AS1 Table C.3.1.1
- Pre-drill holes approximately 1mm smaller than the nail gauge. Example: For a 75mm nail, use a 2.5mm drill
- Nail with slight (0-2°) upward slope
- Fixings to achieve a minimum of 30mm penetration into the framing
- Minimum 50mm from the ends of boards
- Use an accurate packer in the negative detail. Do not rely on clinch nails for spacing

Cavity battens:

- will be fixed by the cladding fixings, which will penetrate the wall framing. Battens only need temporary fixing until the cladding is fixed (E2/AS1 - Table C.3.1.1)
- must always be installed sloping away from the framing
- must have a 5-10mm gap between them

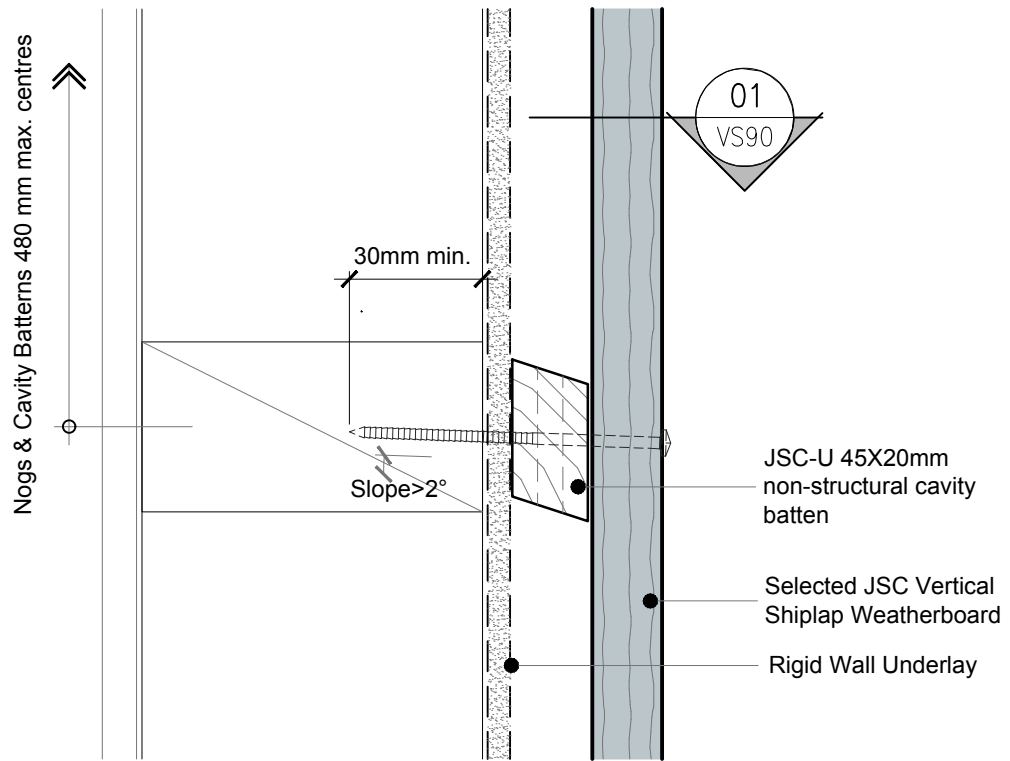

Cross Section 02

• TO BE READ IN CONJUNCTION WITH COMPLETE JSC VERTICLAD SYSTEM LITERATURE

CodeMark
CMNZ30084



DRAWING SCALE 1:2 @ A4	ISSUE DATE 11/02/2026
DRAWING NUMBER JSC 20CR VS91	VERSION 2.6

SEQUENCE :

- | | |
|--------------------------|---|
| 1. Roof and Wall Framing | 8. Apron Flashing |
| 2. Wall Underlay | 9. Flexible Flashing Tape |
| 3. Cavity Battens | 10. Cavity Closure |
| 4. Transition Flashing | 11. Cavity Battens (above Apron Flashing) |
| 5. Fascia Board | 12. Corner Flashing |
| 6. Roof Underlay | 13. Cladding |
| 7. Roofing | 14. Gutter |

Transition tray flashing extended to underside of roofing according to E2/AS1 Figure 5.1.2.4

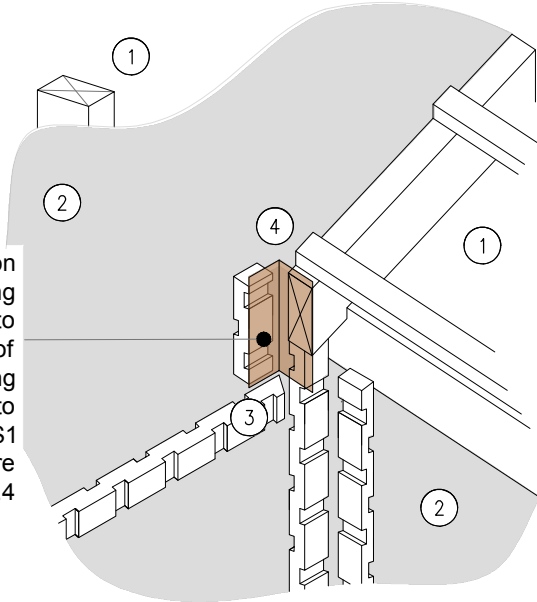

STAGE ONE

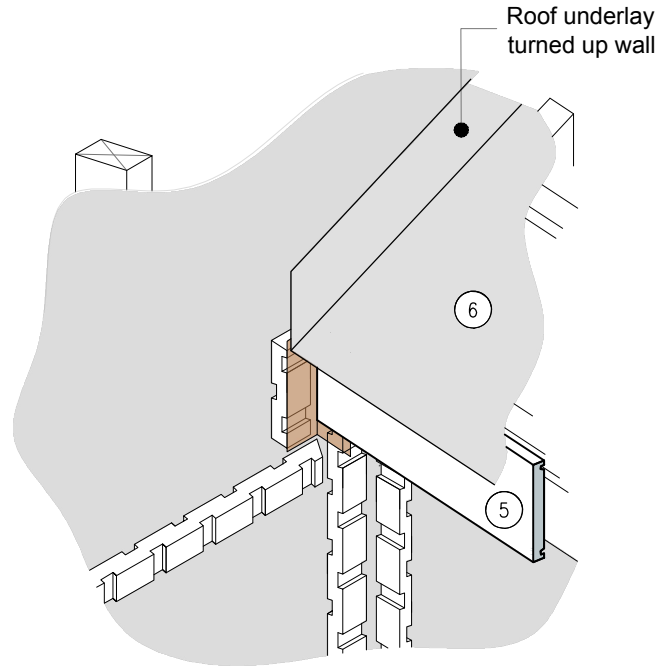

STAGE TWO

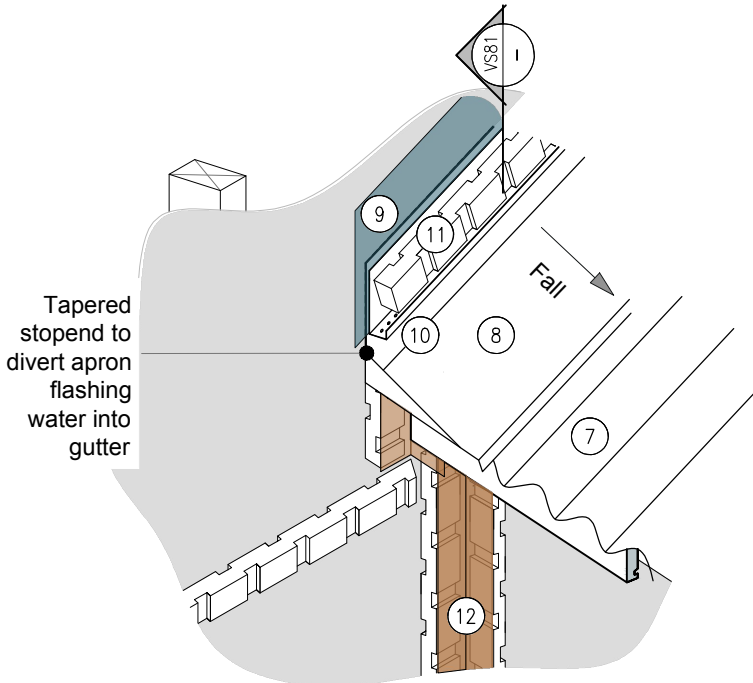

STAGE THREE

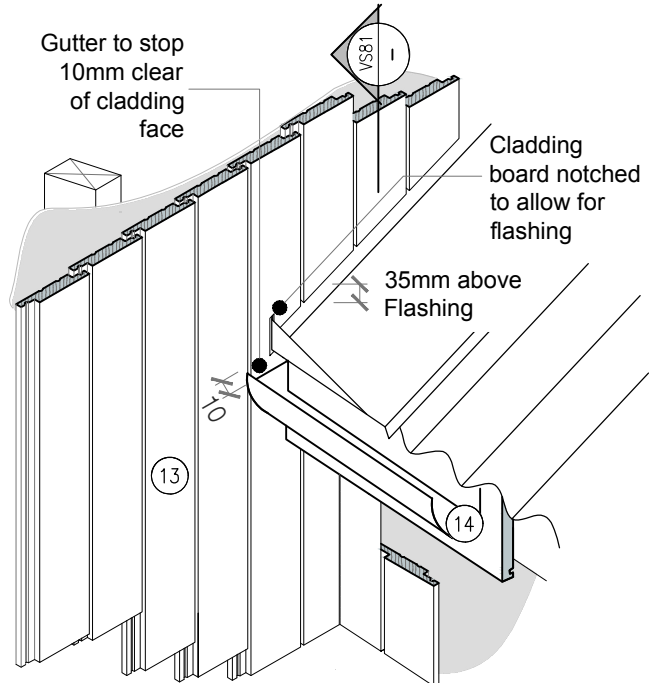

STAGE FOUR

• TO BE READ IN CONJUNCTION WITH COMPLETE JSC VERTICLAD SYSTEM LITERATURE

CodeMark
CMNZ30084



jsc.co.nz
TechHelp@jsc.co.nz | (09) 412 2812

TYPE
VERTICAL SHIPLAP WB - 20MM CAVITY FIX

NAME
Apron Flashing Gutter to Wall

• DETAILS MAY BE SUBJECT TO CHANGE WITHOUT NOTICE



SCAN IT FOR MORE INFORMATION

DRAWING SCALE
1:2 @ A4

ISSUE DATE
11/02/2026

DRAWING NUMBER
JSC 20CR VS92

VERSION
2.6